

DATA SHEET

vibro-meter®

VM600^{Mk2} / VM600 ABE040 and ABE042 system racks



VM600^{Mk2} ABE040 system rack
(empty)



KEY FEATURES AND BENEFITS

- From the vibro-meter® product line
- 19" system racks with a standard height of 6U
- Robust aluminium construction
- Modular concept allows specific cards to be added for machinery protection and/or condition monitoring
- Cabinet or panel mounting
- Backplane supporting the VME bus, the VM600^{Mk2}/VM600 system's Tacho, Raw and Open collector (OC) buses, and power supply distribution
- Uses the VM600^{Mk2}/VM600 RPS6U rack power supply: AC and/or DC input versions
- Power supply check relay

APPLICATIONS

- VM600^{Mk2}/VM600 machinery protection and/or condition monitoring systems

DESCRIPTION

The VM600^{Mk2}/VM600 ABE040 and ABE042 system racks are used to house hardware for the VM600^{Mk2}/VM600 series of machinery protection and/or condition monitoring systems, from Meggitt's vibro-meter® product line.

Two types of VM600^{Mk2}/VM600 ABE04x system rack are available: the ABE040 and the ABE042. These are very similar, differing only in the position of the mounting brackets. Both racks have a standard height of 6U and provide mounting space (rack slots) for up to 12 single-width VM600^{Mk2}/VM600 modules (card pairs), or a combination of single-width and multiple-width modules (cards). These racks are particularly suitable for industrial environments, where equipment must be permanently installed in 19" cabinets or panels.



Information contained in this document may be subject to export control regulations of the European Union, USA or other countries. Each recipient of this document is responsible for ensuring that transfer or use of any information contained in this document complies with all relevant export control regulations. ECN N/A.

DESCRIPTION *(continued)*

The different versions of ABE04x system rack enable different mounting options to support various markets and applications.

The VM600 system rack has an integrated VME backplane which provides the electrical interconnections between the installed VM600^{Mk2}/VM600 modules (cards): power supply, signal processing, input /output, relay and CPUx “rack controller”. It also includes a power supply check relay, available at the rear of the rack, which is used to indicate that the installed RPS6U rack power supplies are operating normally.

Either one or two RPS6U rack power supplies can be installed in a VM600^{Mk2}/VM600 ABE04x system rack. A rack with one RPS6U power supply (330 W version) supports the power requirements for a full rack of modules (cards) in applications with operating temperatures up to 50°C (122°F).

Alternatively, a rack can have two RPS6U power supplies installed in order to either support rack power supply redundancy or in order to supply power to the modules (cards) non-redundantly

over a wider range of environmental conditions (see **Power supply on page 3**).

VM600^{Mk2}/VM600 processing modules (cards) are installed in the front of the rack and the associated input/output modules (cards) are installed in the rear. The input/output modules (cards) provide connectors for the connection of sensors/measurement chains and for the sharing of various signals with external systems such as a DCS or PLC.

In general, VM600^{Mk2}/VM600 ABE04x system racks are configured in the factory before delivery so they are supplied ready-to-use. Optionally, each module (card) can be reconfigured to meet the needs of a particular machinery monitoring application using the appropriate software package from Meggitt vibro-meter[®]: VM600 MPSx or VibroSight[®].

For further information, contact your local Meggitt representative.

SPECIFICATIONS

General

Housing	: Extruded aluminium frame and solid aluminium structural parts. Top and bottom plastic guide strips for VM600 ^{Mk2} /VM600 modules (cards).
Colour	: Aluminium
Power supply	: The VM600 ^{Mk2} /VM600 RPS6U rack power supply is used to provide the VM600 ^{Mk2} /VM600 rack itself and all installed modules (cards) with +5 V _{DC} and ±12 V _{DC} . See also Power supply on page 3 .
Power supply inputs	: Power supply inputs (associated rear panels) typically have an AC and/or DC connector (with RFI filters), on/off switches and fuses. Refer to the <i>VM600^{Mk2}/VM600 RPS6U rack power supplies data sheet</i> for information on power supply inputs, associated rear panels and mains power supply leads (power cords).
Backplane	: VME bus for communication between CPUx modules (cards) and processing modules (cards). Proprietary VM600 ^{Mk2} /VM600 rack buses (Tacho bus, Raw bus and Open collector (OC) bus) for data/signal sharing between modules (cards).

SPECIFICATIONS *(continued)*

Rack slots
(module (card) positions)

- : Front of rack:
- 12 × slots – module (card) positions 03 to 14 – for processing modules (cards) such as MPC4^{Mk2}, XMx16, MPC4 and/or AMC8.
 - 2 × slots – module (card) positions 00 to 01 – for rack controller and communications interface modules (cards) such as CPUM^{Mk2} or CPUx.
 - 1 × slot – module (card) position 02 – reserved for application-specific modules (cards).
- Rear of rack:
- 19 × slots – module (card) positions 00 to 18 – for associated input/output modules (cards) such as IOC4^{Mk2}, XIO16T, IOC4T and/or IOC8T, IOCN^{Mk2} or IOCx, and relay modules such RLC16^{Mk2}, RLC16 and/or IRC4.

See also **Mechanical drawings – front and rear views on page 5.**

Note: In general, associated input/output modules (cards) are required while relay modules (cards) are optional.

Note: For safety reasons, any VM600^{Mk2}/VM600 rack slot not populated by a module (card) must be covered by a blank panel(s).

Galvanic separation

- : Galvanic separation units (GS1xxx) are available for accelerometer and proximity systems mounted in explosive atmospheres. These units cannot be supplied by the rack and require an external power supply. They must be mounted outside the rack in a remote housing or in a cabinet.

Power supply

VM600^{Mk2}/VM600 RPS6U rack power supplies

- : A VM600^{Mk2}/VM600 ABE04x system rack can have either one or two RPS6U rack power supplies installed, as follows:
- 1 × RPS6U power supply (330 W) supports the power requirements for a full rack of modules (cards) in applications with operating temperatures up to 50°C (122°F).
 - 2 × RPS6U power supplies (330 W) – operating redundantly – supports the power requirements for a full rack of modules (cards) in applications with operating temperatures up to 50°C (122°F). With this rack power supply redundancy, if one RPS6U fails, the other will provide 100% of the rack's power requirements so that the rack will continue to operate.
- Note: This is known as a redundant RPS6U rack power supply configuration.
- 2 × RPS6U power supplies (330 W) – operating non-redundantly – supports the power requirements for a full rack of modules (cards) in applications with operating temperatures above 50°C (122°F), where RPS6U output power derating is required.
- Note: Even though two RPS6U rack power supplies are installed in the rack, this is not a redundant RPS6U rack power supply configuration.

Refer to the *VM600^{Mk2}/VM600 RPS6U rack power supplies data sheet* and a *VM600^{Mk2}/VM600 machinery protection system (MPS) hardware manual* for further information.

SPECIFICATIONS *(continued)*

Power supply check relay

Nominal switching capacity (resistive load)	: 4 A / 250 V _{AC} , 3 A / 30 V _{DC}
Maximum switching power (resistive load)	: 1 000 VA, 90 W
Maximum switching voltage	: ±30 V _{RMS} / ±42.4 V _{AC(PEAK)} or 60 V _{DC}
Maximum switching current	: 4 A _{AC} , 3 A _{DC}

Environmental

According to IEC 60068-2 recommendations

Temperature

- Operating : 0 to 70°C (32 to 158°F)
- Storage : -40 to 85°C (-40 to 185°F)

Humidity : 0 to 90%, non-condensing

Vibration : 10 to 55 Hz, 0.35 mm peak, 6 hours in each direction

Shock : 15 g peak, 11 ms, half-sine pulse

Indoor use : Limited to indoor use only

Approvals

Conformity	: European Union (EU) declaration of conformity (CE marking). cCSAus certificate of compliance. EAC marking, Eurasian Customs Union (EACU) certificate/ declaration of conformity.
Electromagnetic compatibility	: IEC/EN 61000-6-2 and IEC/EN 61000-6-4. TR CU 020/2011.
Electrical safety	: IEC/EN 61010-1. TR CU 004/2011.
Vibration	: IEC 60255-21-1 (Class 2)
Environmental management	: RoHS compliant
Russian federal agency for technical regulation and metrology (Rosstandart)	: Pattern approval certificate OC.C.28.004.A N° 60224

Physical

Dimensions	: See Mechanical drawings starting on page 4
Weight	: 6.5 kg (14.3 lb) approx. without RPS6U power supplies and modules (cards)

MECHANICAL DRAWINGS – FRONT AND REAR VIEWS

Front view of ABE040 and ABE042

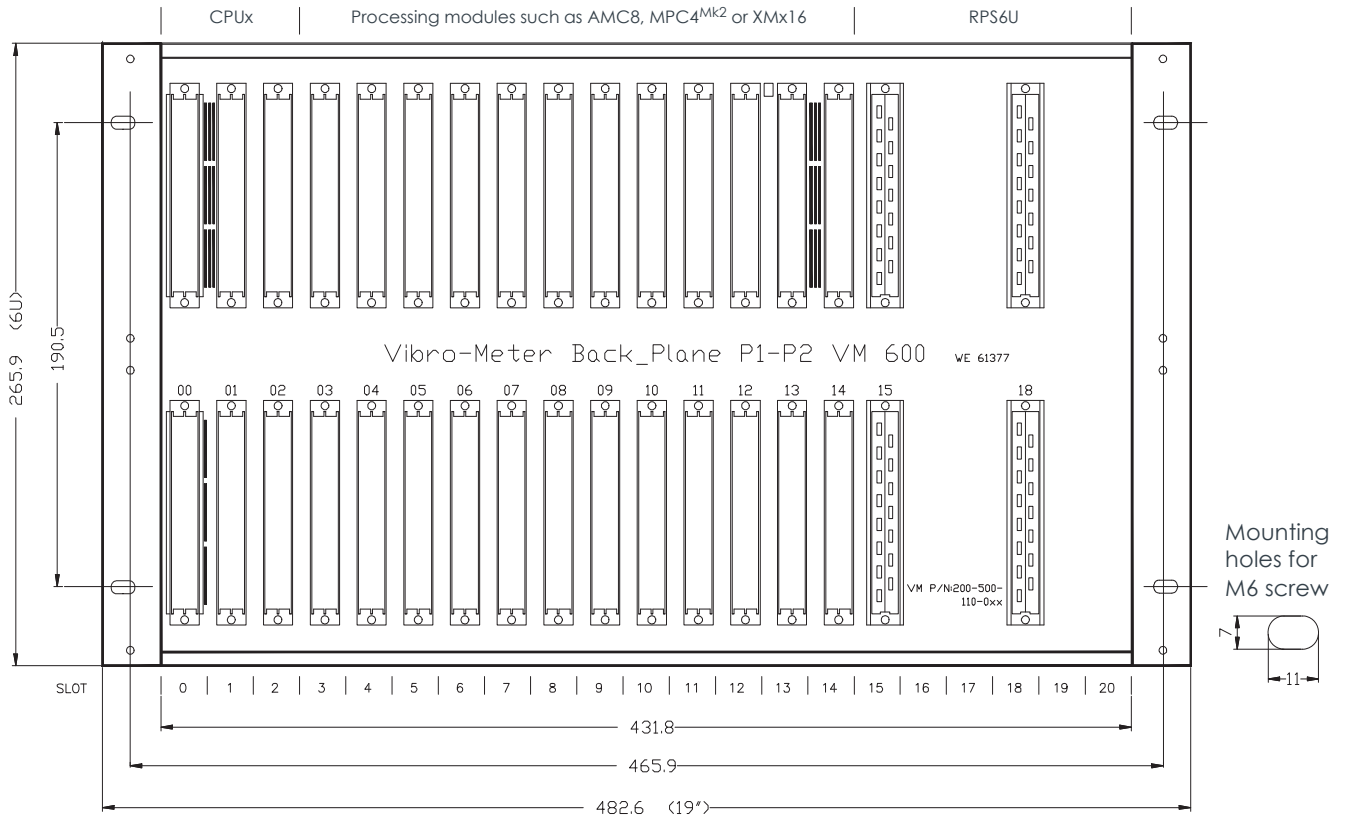

With AC-input RPS6U rack power supply

Rear view of ABE040 and ABE042

With DC-input RPS6U rack DC rear supply

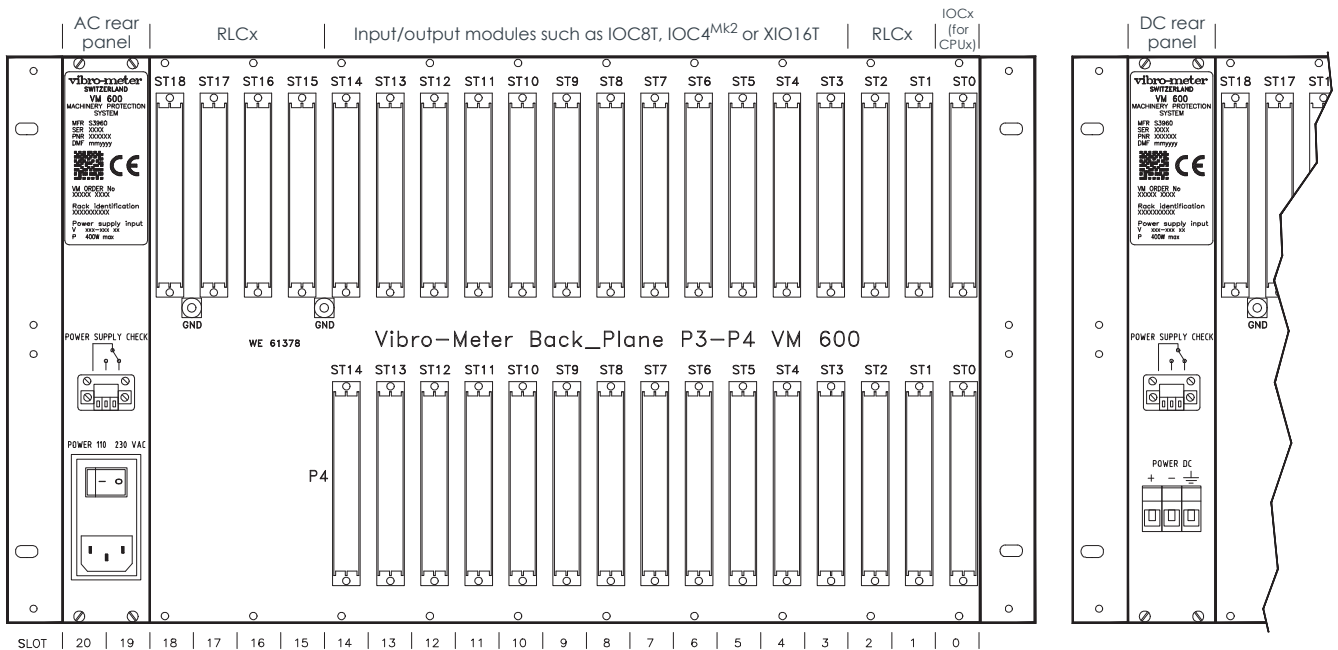

Note: All dimensions are in mm (in) unless otherwise stated.

MECHANICAL DRAWINGS – SIDE AND TOP VIEWS

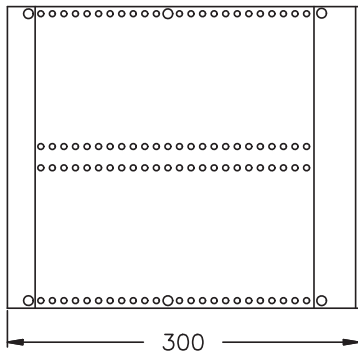

Side view of ABE040

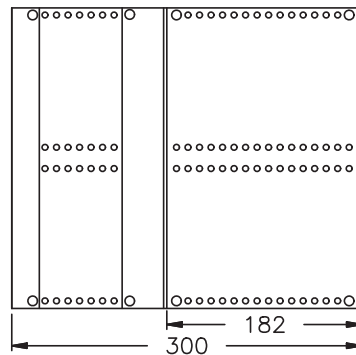

Side view of ABE042

Top view of ABE040

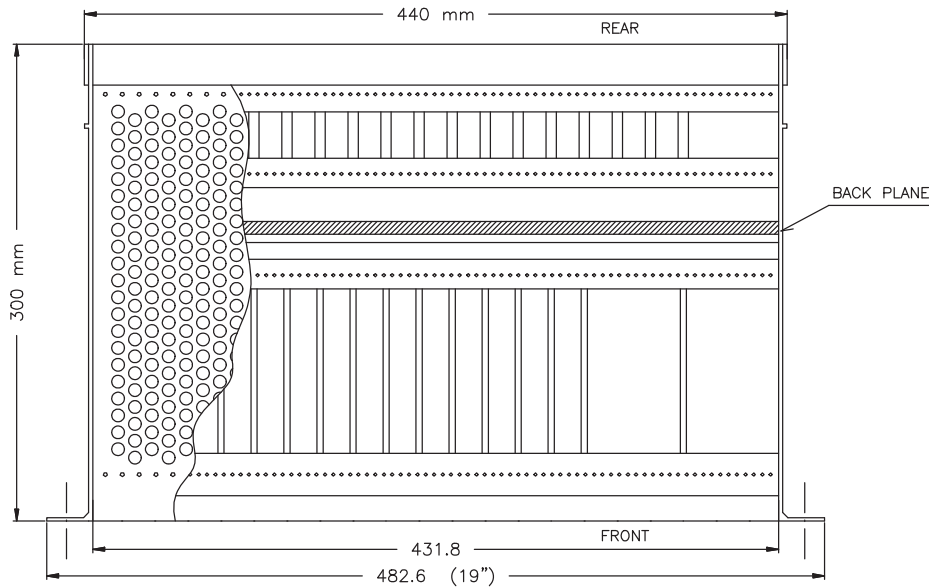

Top view of ABE042

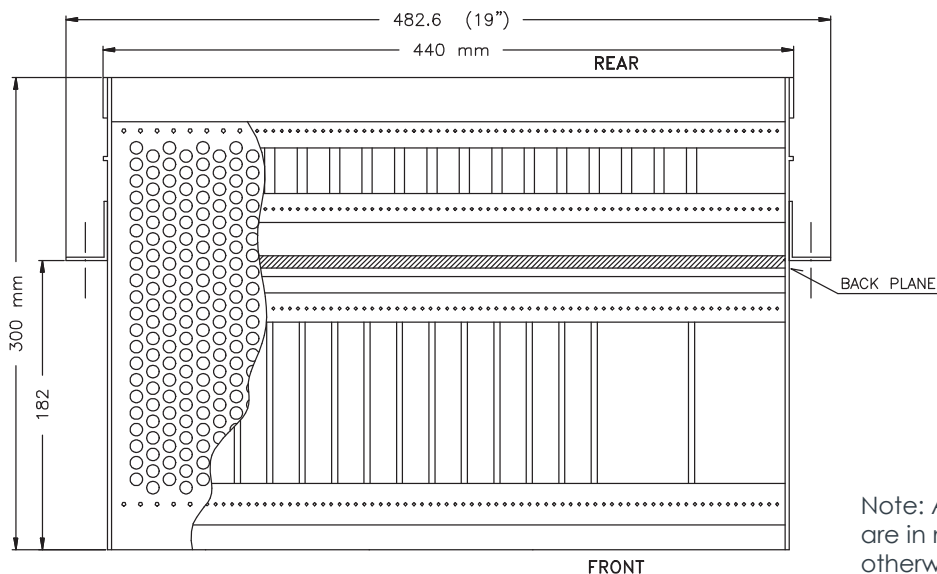

Note: All dimensions are in mm (in) unless otherwise stated.

ORDERING INFORMATION

To order
please
specify

Type	Designation	Ordering number (PNR)
ABE040	Different versions of the VM600 ^{Mk2} ABE040 system rack: – Standard version	204-040-100-016
ABE040	Different versions of the VM600 ^{Mk2} /VM600 ABE040 system rack: – Standard version	204-040-100-015
	– Varnished version, with a conformal coating for additional environmental protection	204-040-100-015L
	– Separate circuits version, in accordance with the IEC 60255-5 standard	204-040-100-115
	– CCSAus version, in accordance with the IEC 61010-1 standard	204-040-100-214
ABE042	Different versions of the VM600 ^{Mk2} /VM600 ABE042 system rack: – Version with mounting brackets positioned at the rear of the rack	204-042-100-01h
	– Varnished version, with a conformal coating for additional environmental protection	204-042-100-01hL
	Different blank panel kits for the front of a VM600 ^{Mk2} ABE04x system rack: – 1 × slot wide / 4 HP (TE)	200-505-011-012
	– 3 × slots wide / 12 HP (TE)	200-505-018-012
	Different blank panel kits for the rear of a VM600 ^{Mk2} ABE04x system rack: – 1 × slot wide / 4 HP (TE)	200-505-011-012
	Different blank panel kits for the front of a VM600 ABE04x system rack: – 1 × slot wide / 4 HP (TE)	200-505-015-011
	– 2 × slots wide / 8 HP (TE)	200-505-016-011
	– 3 × slots wide / 12 HP (TE)	200-505-018-011
	– 4 × slots wide / 16 HP (TE)	200-505-017-011
	Different blank panel kits for the rear of a VM600 ABE04x system rack: – 1 × slot wide / 4 HP (TE)	200-505-011-011
	– 2 × slots wide / 8 HP (TE)	200-505-012-011
	– 4 × slots wide / 16 HP (TE)	200-505-013-011

Notes

In an ordering number (PNR), "h" represents the hardware version.

The standard version of the VM600^{Mk2} ABE040 system rack (PNR 204-040-100-016) and the standard version of the VM600^{Mk2}/VM600 ABE040 system rack (PNR 204-040-100-015 or earlier) are the same, except for the specific artwork/branding/finish. More specifically, the mounting brackets on the side of the ABE040 system rack are bare aluminium for the VM600^{Mk2} versions and painted for the VM600^{Mk2}/VM600 versions. See also **Ordering guidelines on page 8**.

For safety reasons, any VM600^{Mk2}/VM600 ABE04x system rack slot not populated by a module (card) must be covered by a blank panel(s).

(The width of a 19" rack is typically measured in horizontal pitch (HP) units of 5.08 mm (0.2"), also known as standard width (TE) units. For the VM600^{Mk2}/VM600 ABE04x System racks, a 1 × slot wide blank panel suitable for covering one module (card) position corresponds to 4 HP (TE), a 2 × slots wide blank panel corresponds to 8 HP (TE), a 3 × slots wide blank panel corresponds to 12 HP (TE) and so on.)

When only one RPS6U power supply is installed in a VM600^{Mk2}/VM600 ABE04x system rack (PS1 in rack slots 18 to 20), the unused power supply position (PS2 in rack slots 15 to 17) should be populated with a blank panel(s).

ORDERING GUIDELINES

The ordering numbers (PNRs) given in **Ordering information on page 7** of this data sheet should be used when ordering a VM600^{Mk2}/VM600 ABE04x system rack and/or blank panels as individual system components for use as a replacement or spare part.

However, when ordering these components with other system components as part of a complete VM600^{Mk2}/VM600 machinery monitoring system, then a VM600SYS-based ordering number should be used. Contact your local Meggitt representative for further information.

RELATED PRODUCTS

VM600^{Mk2} (second generation)

ABE056	VM600 ^{Mk2} /VM600 slimline rack	: Refer to corresponding data sheet
ASPS	VM600 ^{Mk2} /VM600 auxiliary sensor power supply	: Refer to corresponding data sheet
CPUM ^{Mk2} + IOCN ^{Mk2}	VM600 ^{Mk2} rack controller and communications interface module	: Refer to corresponding data sheet
MPC4 ^{Mk2} + IOC4 ^{Mk2}	VM600 ^{Mk2} machinery protection and condition monitoring module	: Refer to corresponding data sheet
RLC16 ^{Mk2}	VM600 ^{Mk2} relay module	: Refer to corresponding data sheet
RPS6U	VM600 ^{Mk2} /VM600 rack power supplies	: Refer to corresponding data sheet
XMx16 + XIO16T	VM600 ^{Mk2} /VM600 condition monitoring modules	: Refer to corresponding data sheet

VM600 (first generation)

ABE056	VM600 ^{Mk2} /VM600 slimline rack	: Refer to corresponding data sheet
AMC8 and IOC8T	VM600 analog monitoring card pair	: Refer to corresponding data sheet
ASPS	VM600 ^{Mk2} /VM600 auxiliary sensor power supply	: Refer to corresponding data sheet
CPUM and IOCN	VM600 modular CPU card and input/output card. Note: With a front-panel display and support for Modbus RTU/TCP or PROFINET.	: Refer to corresponding data sheet
CPUR and IOCR	VM600 rack controller and communications interface card pair. Note: With rack controller redundancy and support for Modbus RTU/TCP.	: Refer to corresponding data sheet
CPUR2 and IOCR2	VM600 rack controller and communications interface card pair. Note: With mathematical processing of fieldbus data and support for Modbus TCP and PROFIBUS.	: Refer to corresponding data sheet
IRC4	VM600 intelligent relay card	: Refer to corresponding data sheet
MPC4 and IOC4T	VM600 machinery protection card pair	: Refer to corresponding data sheets
RLC16	VM600 relay card	: Refer to corresponding data sheet
RPS6U	VM600 ^{Mk2} /VM600 rack power supplies	: Refer to corresponding data sheet
XMx16 + XIO16T	VM600 ^{Mk2} /VM600 condition monitoring modules	: Refer to corresponding data sheet

Meggitt (Meggitt PLC) is a leading international engineering company, headquartered in England, that designs and delivers high-performance components and subsystems for aerospace, defence and selected energy markets. Meggitt comprises four customer-aligned divisions: Airframe Systems, Engine Systems, Energy & Equipment and Services & Support.

The Energy & Equipment division includes the Energy Sensing and Controls product group that specialises in sensing and monitoring solutions for a broad range of energy infrastructure, and control valves for industrial gas turbines, primarily for the Power Generation, Oil & Gas and Services markets. Energy & Equipment is headquartered in Switzerland (Meggitt SA) and incorporates the vibro-meter[®] product line, which has over 65 years of sensor and systems expertise and is trusted by original equipment manufacturers (OEMs) globally.



All information in this document, such as descriptions, specifications, drawings, recommendations and other statements, is believed to be reliable and is stated in good faith as being approximately correct, but is not binding on Meggitt (Meggitt SA) unless expressly agreed in writing. Before acquiring and/or using this product, you must evaluate it and determine if it is suitable for your intended application. You should also check our website at www.meggittsensing.com/energy for any updates to data sheets, certificates, product drawings, user manuals, service bulletins and/or other instructions affecting the product.

Unless otherwise expressly agreed in writing with Meggitt SA, you assume all risks and liability associated with use of the product. Any recommendations and advice given without charge, whilst given in good faith, are not binding on Meggitt SA. Meggitt (Meggitt SA) takes no responsibility for any statements related to the product which are not contained in a current Meggitt SA publication, nor for any statements contained in extracts, summaries, translations or any other documents not authored and produced by Meggitt SA.

The certifications and warranties applicable to the products supplied by Meggitt SA are valid only for new products purchased directly from Meggitt SA or from an authorised distributor of Meggitt SA.

In this publication, a dot (.) is used as the decimal separator and thousands are separated by thin spaces. Example: 12345.67890.

Copyright© 2021 Meggitt SA. All rights reserved. The information contained in this document is subject to change without prior notice.

Sales offices

Meggitt has offices in more than 30 countries. For a complete list, please visit our website.

Local representative

Head office



Meggitt SA
Route de Moncor 4
Case postale
1701 Fribourg
Switzerland

Tel: +41 26 407 11 11

Fax: +41 26 407 13 01

energy@ch.meggitt.com

www.meggittsensing.com/energy

www.meggitt.com