

DATA SHEET

vibro-meter®

VibroSmart® VSA301 buffered output amplifier



VSA301
buffered output amplifier

KEY FEATURES AND BENEFITS

- VibroSight® compatible hardware from the vibro-meter® product line
- Designed for operation with the VibroSmart® VSV300 monitoring module
- Two dynamic channels with:
Current or voltage inputs
AC or DC coupling
Fixed-gain amplification of 10
Voltage and current outputs
- One tachometer channel with:
Current or voltage input
Offset removal
3.3 to 5.0 V digital level translation
Voltage output
- Voltage signal transmission over short distances, up to 5 m
- Current signal transmission over long distances, up to 500 m
- Removable screw-terminal connectors
- Robust enclosure with DIN rail mounting adaptor



APPLICATIONS

- Provides API 670 compliant buffered transducer outputs via front-panel BNC connectors for one VSV300 module
- Short-distance signal transmission using one VSA301 module and long-distance signal transmission using two VSA301 modules
- Machinery protection and/or condition monitoring



Information contained in this document may be subject to export control regulations of the European Union, USA or other countries. Each recipient of this document is responsible for ensuring that transfer or use of any information contained in this document complies with all relevant export control regulations. ECN N/A.

DESCRIPTION

Introduction

The VibroSmart® distributed monitoring system (DMS) is a system of modular and scalable products designed for condition monitoring and machinery protection applications for power generation turbines, oil and gas applications and auxiliary balance-of-plant equipment.

VibroSmart® modules can be mounted directly on machinery, reducing the need for costly cabling, because VibroSmart is designed and certified to work in extremes, such as harsh industrial environments characterized by potentially explosive atmospheres (Ex Zone 2), high temperatures (70°C, 158°F) and high mechanical stress. VibroSmart complements the VM600 series of rack-based solutions from Meggitt's vibro-meter® product line and is compatible with the same VibroSight® software.

The VibroSmart VSA301 buffered output amplifier connects to a VibroSmart VSV300 monitoring module in order to amplify and buffer its buffered transducer "raw" outputs. More specifically, a VSA301 amplifier makes the "raw" transducer inputs to a VSV300 module's dynamic channels available at their original amplitude on the VSA301's front-panel BNC connectors. In addition, two VSA301 amplifiers can be combined in order to allow the transmission of the buffered output signals over distances up to 500 m.

VibroSmart distributed monitoring system

A VibroSmart® distributed monitoring system (DMS) is a network of small and economical modules providing measurement, communications or other functions that are connected together in distributed, networked measurement blocks in order to provide the functionality normally offered by rack-based machinery monitoring systems. A VibroSmart system consists of one or more measurement blocks, each containing up to sixteen VibroSmart modules, such as VSV30x monitoring modules, a power supply and an optional host computer running the VibroSight® software.

A measurement block is a logical grouping of VibroSmart modules that allows data such as tachometer, trigger and alarm information to be shared, for example, in order to monitor the same machine. Measurement blocks are configured using the VibroSight software.

Note: A VibroSmart DMS is limited to a maximum of 8 measurement blocks without VibroSmart VSN010 real-time industrial Ethernet switches but if each measurement block contains a VSN010, then a higher number of measurement blocks can be achieved, limited only by overall system performance (network traffic, VibroSight computer configuration and so on).

A VibroSmart module consists of an electronics module (providing configurable machinery monitoring functions) that clips into a VibroSmart terminal base, which mounts on a DIN rail. A range of plug-in signal conditioners and plug-in communications interfaces that interface directly with VibroSmart modules will be available to provide an integrated solution for interfacing to sensors and fieldbuses.

VibroSmart terminal bases incorporate buses and connectors to provide all of the I/O connections required to interface to a VibroSmart module. Terminal bases also include non-volatile memory to store the configuration of the attached VibroSmart module, which allows modules to be hot-swapped. Modules and terminal bases use mechanical key-coding for a system that is simple to operate and use.

Different VibroSmart modules, terminal bases, plug-in signal conditioners and plug-in communications interfaces can be combined to offer unique combinations of functionality, versatility and safety assurance. In this way, a monitoring system can be built to meet the exact needs of an application resulting in a more cost-effective and reliable solution.

VSA301 buffered output amplifier

The VSA301 buffered output amplifier is designed for operation with the three buffered transducer "raw" outputs from a VSV300 monitoring module, that is, the VSA301 provides two dynamic channels and one tachometer channel.

For each dynamic channel signal, a VSA301 provides an independent analog amplifier with a fixed gain of 10 (20 dB). The dynamic channels incorporate a DC filter can be enabled for each input signal in order to block the DC component, if required. These channels also include voltage to current (V to I) mode and current to voltage

DESCRIPTION *(continued)*

(I to V) mode circuitry that allows the transmission of analog signals over long distances.

For the tachometer channel signal, a VSA301 provides a digital level-translator that shifts from 3.3 V to 5.0 V logic. This channel removes any offset then reconstructs the signal, so it is only suitable for an VSV300 module auxiliary input channel configured as a tachometer input (not a DC input). The auxiliary channel also includes line driver circuitry that allows the transmission of digital signals over long distances.

As the buffered outputs for a VSV300 module's dynamic channels are provided with a voltage transfer ratio of 0.1 V/V (output-to-input ratio of 1:10) and the VSA301 provides an amplification of 10, a VSV300 module's dynamic channel signals are available at their original "raw" amplitude on the front panel of a VSA301.

The VSA301 buffered output amplifier can be used in two different ways: for voltage transmission over short distances and for current transmission over long distances. Voltage transmission uses single-ended voltage signals for each VSA301 output. However, current transmission uses current loop signals for the dynamic channels and a voltage signal for the auxiliary channel.

Note: The way a VSA301 is used affects the dynamic input channels (CH1 and CH2) only, as these outputs can be transmitted as either a voltage or as a current. The auxiliary input channel (AUX) output is always transmitted as a voltage.

Voltage transmission over short distances up to 5 m requires one VSA301 configured for the voltage to voltage (V to V) mode of operation. See **Block diagram on page 4**.

Current transmission over long distances up to 500 m requires two VSA301 amplifiers: the first VSA301 (the transmitter) configured for the voltage to current (V to I) mode of operation and second VSA301 (the receiver) configured for the current to voltage (I to V) mode of operation. See **Block diagram on page 4**.

Irrespective of the way a VSA301 is used (voltage or current transmission), the buffered outputs from a VSV300 module are always available at their original amplitude on the VSA301's front-panel BNC connectors.

Externally accessible DIP switches are used to configure a VSA301 for the required mode of operation (V to V, V to I or I to V). DIP switches are also used to select the DC filter.

Applications information

A single VSA301 buffered output amplifier can be used wherever the "raw" transducer inputs to a VSV300 monitoring module's dynamic channels are required at their original amplitude. For example, to connect to test equipment and instrumentation using BNC outputs and meet the requirements of the API standard 670 for machinery protection systems.

A pair of VSA301 amplifiers can be used to transmit the buffered transducer "raw" outputs from a VSV300 monitoring module over distances up to 500 m and provide them at their original amplitude. This is particularly useful for a VibroSmart DMS installed in a potentially explosive atmosphere (Ex Zone 2) where for example, it allows the buffered transducer outputs to be monitored when a machine is being balanced – without first having to shut down the machine in order to connect additional test equipment.

For specific applications and other information, contact your local Meggitt representative.

BLOCK DIAGRAM

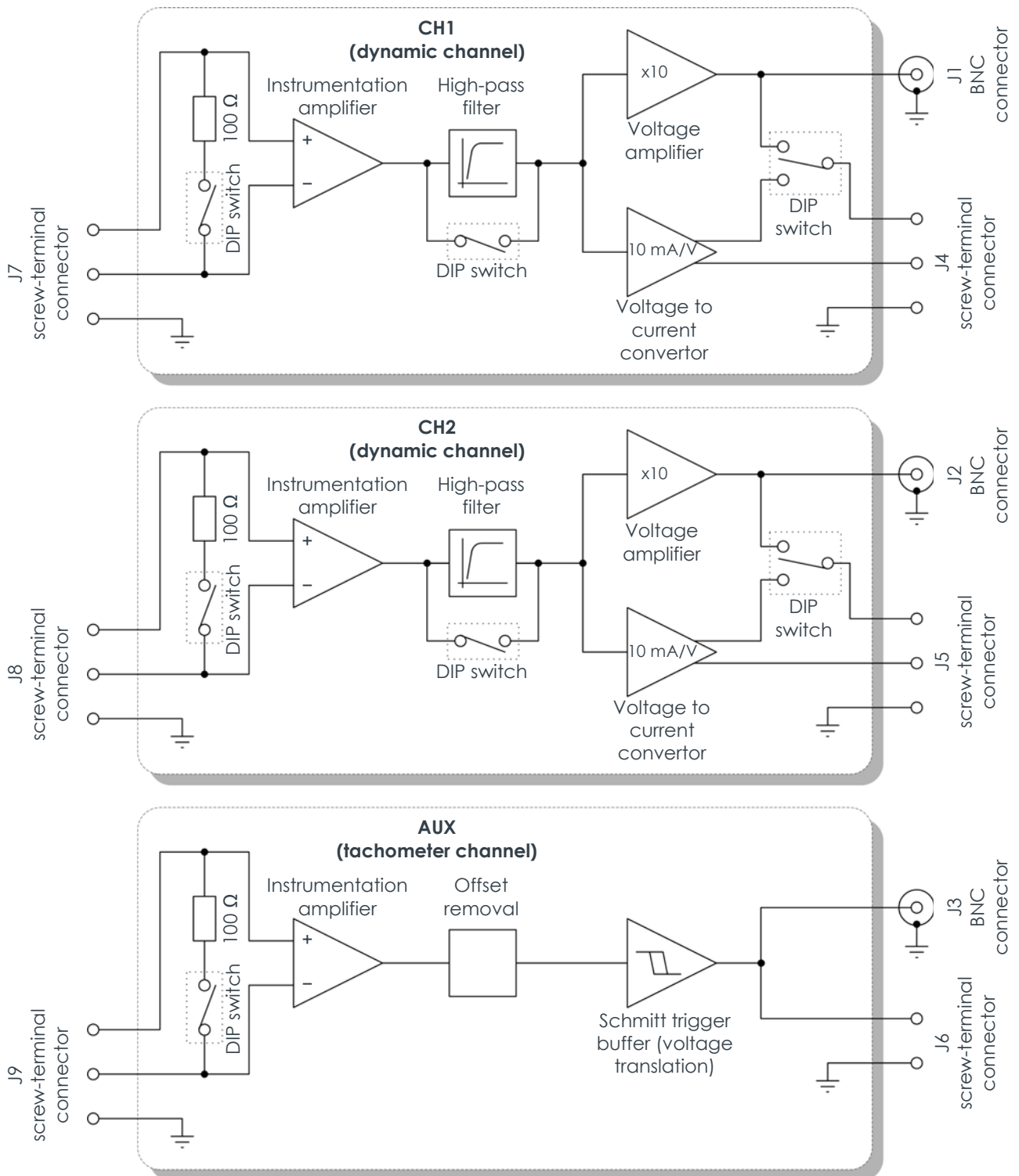

SPECIFICATIONS

Dynamic channel inputs

Type	: Analog processing – configurable V to V or I to V input stage, followed by a configurable high-pass filter (that is, AC or DC coupling), then amplifiers providing a single-ended voltage signal output and a configurable differential output (current or voltage).
Number of independent channels	: 2
Input range	
• Voltage	: $2 V_{DC} \pm 2 V_{AC}$ (PEAK-TO-PEAK)
• Current	: ± 25 mA
	Note: The signal transmission mode (current or voltage) for each dynamic input signal is selected using a DIP switch.
Input impedance	
• Voltage	: ≥ 200 k Ω
• Current	: 150 Ω
Filtering	
• Type	: DC filter (first-order high-pass)
• Cutoff frequency	: 1 Hz (-3 dB)
• Selection	: Configured using DIP switch. See Configuration on page 9 .
Bandwidth	: 0 Hz to 20 kHz
Protection against over-voltages	: Permanent protection up to \pm power supply input voltage. See Power supply (input) on page 9 .

Auxiliary (tachometer) channel input

Type	: Digital processing – configurable V to V or I to V input stage, followed by offset removal (that is, AC coupling), then a Schmitt trigger buffer providing a single-ended voltage signal output.
Input range	
• Voltage	: 0 to 0.8 V for a "low". 2.0 to 5.5 V for a "high". Note: As the input signal has its offset removed and is reconstructed, non-rectangular input signals can be used.
• Current	: ± 25 mA Note: The signal transmission mode (current or voltage) for the auxiliary input signal is selected using a DIP switch.
Input impedance	
• Voltage	: ≥ 50 k Ω
• Current	: 50 Ω
Protection against over-voltages	: Permanent protection up to \pm power supply input voltage. See Power supply (input) on page 9 .

Note: The VSA301's auxiliary input is a digital channel and is suitable for use with a VSV300 monitoring module's auxiliary input channel that is configured as a tachometer input (not a DC input).

SPECIFICATIONS *(continued)*

Dynamic channel outputs

Note: The VSA301 provides the dynamic channel outputs via the BNC connectors (J1 and J2) on the front panel of the module and via the screw-terminal connectors (J4 and J5) on the top of the module: The dynamic channel outputs on the BNC connectors are provided as a voltage signal (single-ended). The dynamic channel outputs on the screw-terminal connectors are provided as either a current or a voltage signal (differential), depending on the signal transmission mode selected using a DIP switch.

Transfer ratio (gain)

- Voltage input : 10 V/V in V to V mode (output-to-input ratio of 10:1, non-inverting).
- Current input : 10 mA/1 V (non-inverting) in V to I mode.
1 V/10 mA (non-inverting) in I to V mode.

Amplitude accuracy (gain error)

- : ≤0.4% (bandwidth from 10 Hz to 2 kHz)
- Note: The overall gain error for a VSV300 monitoring module's dynamic output signal that is transmitted via two VSA301s is ≤1%.

Phase accuracy

- Voltage to voltage (V to V mode) : ≤1° (bandwidth from 10 Hz to 2 kHz)
- Current : TBC

Total harmonic distortion (THD)

- Voltage : -60 dB (V to V mode)
- Current : -54 dB (V to I and I to V modes)

Output impedance

- Voltage : ≤5 Ω
- Current : ≥100 kΩ

Output current

- Voltage : ≤3 mA
- Current : ≤30 mA

Frequency bandwidth : 0 Hz to 50 kHz (I to V and V to V modes)

Dynamic range : ≥60 dB

DC offset : ≤10 mV

Admissible load on output

- BNC : Able to drive up to 5 m of cable with a typical capacitance of 100 pF
- Screw-terminal connector : Able to drive up to 500 m of cable with a typical capacitance of 50 nF.
(The typical cable for connection over the screw-terminal connector has a cross section of 0.5 mm² and a capacitance of 90 pF/m.)

Protection against short-circuits : Permanent protection

Auxiliary channel output

Note: The VSA301 provides the auxiliary channel output via the BNC connector (J3) on the front panel of the module and via the screw-terminal connector (J6) on the top of the module.

The auxiliary channel output on the BNC connector and on the screw-terminal connector is provided as a voltage signal (single-ended).

Transfer ratio (gain)

- Voltage input : 3.3 V to 5.0 V digital logic conversion (TTL-compatible signal) in V to V mode
- Current input : 1 V/10 mA (non-inverting) followed by 3.3 V to 5.0 V digital logic conversion (TTL-compatible signal) in I to V mode

SPECIFICATIONS *(continued)*

Output voltage	: ≤0.55 V for a “low”. ≥3.8 V for a “high”.
Output current	: ±32 mA max.
Speed / frequency measurement	: Up to 100 000 RPM / 1 667 Hz, over up to 500 m of cable, for a one pulse per rotation signal such as a 1/REV pulse reference. Signals with more multiple pulses per rotation may have limitations (amplitude and phase) that prevent transmission over long cables.
Delay	: ≤10 μs (input to output, 90% of final voltage, at the end of the cable)
Admissible load on output	
• BNC	: Able to drive up to 5 m of cable with a typical capacitance of 100 pF
• Screw-terminal connector	: Able to drive up to 500 m of cable with a typical capacitance of 50 nF. (The typical cable for connection over the screw-terminal connector has a cross section of 0.5 mm ² and a capacitance of 90 pF/m.) Note: Long cables will distort the auxiliary channel signal but this distortion does affect the edge-based detection of the signal. In addition, long cables introduce a delay, dependent on cable length.
Protection against short-circuits	: Permanent protection

Environmental

Operating	
• Temperature	: -20 to 70°C (-4 to 158°F)
• Humidity	: 0 to 90% non-condensing
Storage	
• Temperature	: -40 to 85°C (-40 to 185°F)
• Humidity	: 0 to 95% non-condensing
Protection rating (according to IEC 60529)	: IP20. It is also possible to deploy VibroSmart modules and devices within an industrial housing in order to attain a rating of IP56. Contact Meggitt for further information.





For Ex Zone 2 applications, a protection rating of at least IP54 (or equivalent) is mandatory.

SPECIFICATIONS *(continued)*

Potentially explosive atmospheres

Ex approved versions for use in hazardous areas

Type of protection Ex nA: non sparking apparatus		
Europe	EC type examination certificate	LCIE 15 ATEX 1014 X II 3 G (Zone 2) Ex nA IIC T6...T4 Gc
International	IECEX certificate of conformity	IECEX LCIE 15.0024X Ex nA IIC T6...T4 Gc
Russian Federation	EAЭC RU certificate of conformity	EAЭC RU C-CH.AA87.B.00369/20 2Ex nA IIC T6...T4 Gc X

-  For specific parameters of the mode of protection concerned and special conditions for safe use, refer to the Ex certificates that are available from Meggitt SA.
-  When using protection mode “Ex nA” (non-sparking), the user must ensure that the VSA301 buffered output amplifier is installed in an industrial housing or enclosure that ensures a protection rating of at least IP54 (or equivalent).
-  For the most recent information on the Ex certifications that are applicable to this product, refer to the Ex product register (PL-1511) document that is available from Meggitt SA.

Approvals

Conformity	: CE marking, European Union (EU) declaration of conformity. EAC marking, Eurasian Customs Union (EACU) certificate/ declaration of conformity.
Electromagnetic compatibility	: EN 61000-6-2:2005. EN 61000-6-4:2007 + A1:2011. EN 61326-1:2006. TR CU 020/2011.
Electrical safety	: EN 61010-1:2010. TR CU 004/2011.
Environmental management	: RoHS compliant (2011/65/UE)
Hazardous areas	: Ex approved (see Potentially explosive atmospheres on page 8)
Russian federal agency for technical regulation and metrology (Rosstandart)	: Pattern approval certificate CH.C.28.004.A N° 60224

SPECIFICATIONS *(continued)*

Configuration

Signal transmission	: Externally accessible DIP switches are used to configure a VSA301 in one of three modes of operation: <ul style="list-style-type: none">• Voltage to voltage (V to V) - required by a single VSA301 being used for voltage transmission over short distances.• Voltage to current (V to I) - required by the first of two VSA301s being used for current transmission over long distances (that is, the transmitter VSA301).• Current to Voltage (I to V) - required by the second of two VSA301s being used for current transmission over long distances (that is, the receiver VSA301). Note: Voltage to current conversion (V to I mode) is available for dynamic channel outputs only.
Filtering	: Externally accessible DIP switches are used to configure optional DC filtering for the dynamic input channels (CH1 and CH2) only.

Power supply (input)

Voltage	: 24 V _{DC} nominal (+16 to +32 V _{DC} input range)
Power consumption	: <3 W
Inrush current	: 500 mA max.
Reverse-polarity protection	: Yes
Over-current protection	: 1.5 A, polymeric PTC resettable fuse on the +24 V _{DC} supply

LED indicator

Power	: Indicates the status of the device's power supplies (input and internal)
-------	--

Connectors

J1, front panel (top)	: BNC connector (female). Amplified version of CH1 input signal.
J2, front panel (centre)	: BNC connector (female). Amplified version of CH2 input signal.
J3, front panel (bottom)	: BNC connector (female). Level-translated version of AUX input signal.
J4, top front	: 4-contact screw-terminal connector. CH1 outputs.
J5, top centre	: 4-contact screw-terminal connector. CH2 outputs.
J6, top rear	: 4-contact screw-terminal connector. AUX output and power supply input.
J7, bottom front	: 4-contact screw-terminal connector. CH1 inputs.
J8, bottom centre	: 4-contact screw-terminal connector. CH2 inputs.
J9, bottom rear	: 4-contact screw-terminal connector. AUX inputs.

SPECIFICATIONS *(continued)*

Physical

Module mounting	: The VSA301 amplifier mounts directly on a TH 35 DIN rail (according to EN 50022 / IEC 60715). For example, TH 35-7.5 or TH 35-15.
Connection to a VSV300 monitoring module	: The buffered transducer "raw" outputs from a VSV300 monitoring module (single-ended voltages available on the J2 connector of a VSV300 + VSB300) are connected as inputs to a VSA301 using the J7, J8 and J9 screw-terminal connectors on the bottom of the device. The amplified output signals from a VSA301 are always available as single-ended voltages on the J1, J2 and J3 BNC connectors on the front panel of the device.
Connection to test equipment (V to V mode)	: When configured for voltage signal transmission using the DIP switches, the amplified output signals for the dynamic channels (CH1 and CH2) and the auxiliary channel (AUX) of a VSA301 are also available as single-ended voltages on the J4, J5 and J6 screw-terminal connectors on the top of the device. The voltage transmission of these signals is suitable for short distances, up to 5 m, and is typically used for the connection of test equipment. Note: This is in addition to the voltage signals available on the J1, J2 and J3 BNC connectors.
Connection to another VSA301 amplifier (V to I and I to V modes)	: When configured for current signal transmission using the DIP switches, the amplified output signals for the dynamic channels (CH1 and CH2) of a VSA301 are also available as differential currents on the J4 and J5 screw-terminal connectors screw-terminal connectors on the top of the device. The current transmission of these signals is suitable for long distances, up to 500 m, to a second VSA301 which converts the current signals back to voltages available on the second VSA301s connectors. The amplified output signal for the auxiliary channel (AUX) of a VSA301 is always available as single-ended voltage on the J6 screw-terminal connector on the top of the device. Note: This is in addition to the voltage signals available on the J1, J2 and J3 BNC connectors.
Connection to a power supply	: The VSA301 is connected to the external +24 V _{DC} supply via the J6 screw-terminal connectors on the top of the device.
Dimensions	: See Mechanical drawing on page 11
Weight	: 200 g (0.44 lb) approx.

MECHANICAL DRAWING

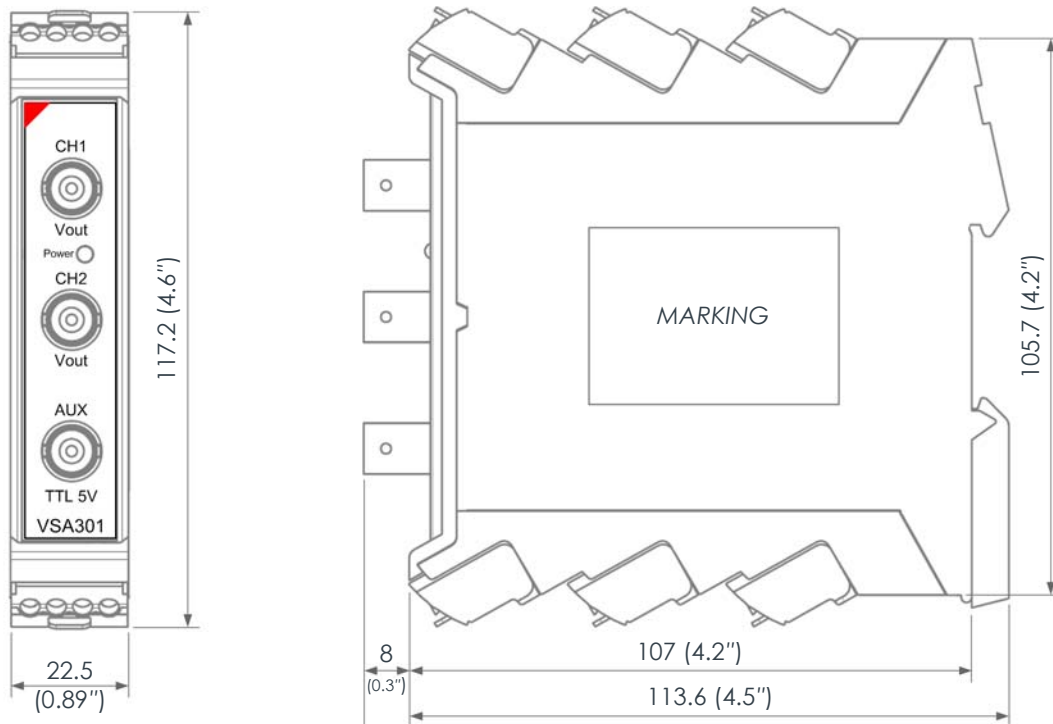

Note: All dimensions in mm (in) unless otherwise stated.

ORDERING INFORMATION

To order please specify

Type	Designation	Ordering number (PNR)
VSA301	VibroSmart buffered output amplifier	600-025

RELATED PRODUCTS

APF19x	24 V _{DC} power supplies	: Refer to corresponding data sheets
APF20x	24 V _{DC} power supplies with Ex approval	: Refer to corresponding data sheets
VSA00x	VibroSmart [®] BNC cable assemblies and patch panels	: Refer to corresponding data sheet
VSI010 + VSB010	VibroSmart [®] communications interface module	: Refer to corresponding data sheet
VSN010	VibroSmart [®] real-time Ethernet switch	: Refer to corresponding data sheet
VSV300 + VSB300	VibroSmart [®] monitoring module	: Refer to corresponding data sheet
VSV301 + VSB300	VibroSmart [®] monitoring module	: Refer to corresponding data sheet
VibroSight	VibroSight [®] machinery monitoring system software	: Refer to corresponding data sheet

Meggitt (Meggitt PLC) is a leading international engineering company, headquartered in England, that designs and delivers high-performance components and subsystems for aerospace, defence and selected energy markets. Meggitt comprises four customer-aligned divisions: Airframe Systems, Engine Systems, Energy & Equipment and Services & Support.

The Energy & Equipment division includes the Energy Sensing and Controls product group that specialises in sensing and monitoring solutions for a broad range of energy infrastructure, and control valves for industrial gas turbines, primarily for the Power Generation, Oil & Gas and Services markets. Energy & Equipment is headquartered in Switzerland (Meggitt SA) and incorporates the vibro-meter[®] product line, which has over 65 years of sensor and systems expertise and is trusted by original equipment manufacturers (OEMs) globally.



All information in this document, such as descriptions, specifications, drawings, recommendations and other statements, is believed to be reliable and is stated in good faith as being approximately correct, but is not binding on Meggitt (Meggitt SA) unless expressly agreed in writing. Before acquiring and/or using this product, you must evaluate it and determine if it is suitable for your intended application. You should also check our website at www.meggittsensing.com/energy for any updates to data sheets, certificates, product drawings, user manuals, service bulletins and/or other instructions affecting the product.

Unless otherwise expressly agreed in writing with Meggitt SA, you assume all risks and liability associated with use of the product. Any recommendations and advice given without charge, whilst given in good faith, are not binding on Meggitt SA. Meggitt (Meggitt SA) takes no responsibility for any statements related to the product which are not contained in a current Meggitt SA publication, nor for any statements contained in extracts, summaries, translations or any other documents not authored and produced by Meggitt SA.

The certifications and warranties applicable to the products supplied by Meggitt SA are valid only for new products purchased directly from Meggitt SA or from an authorised distributor of Meggitt SA.

In this publication, a dot (.) is used as the decimal separator and thousands are separated by thin spaces. Example: 12345.67890.

Copyright© 2022 Meggitt SA. All rights reserved. The information contained in this document is subject to change without prior notice.

Sales offices

Meggitt has offices in more than 30 countries. For a complete list, please visit our website.

Local representative

Head office



Meggitt SA
Route de Moncor 4
Case postale
1701 Fribourg
Switzerland

Tel: +41 26 407 11 11
Fax: +41 26 407 13 01

energy@ch.meggitt.com

www.meggittsensing.com/energy
www.meggitt.com

DATA SHEET