

DATA SHEET

vibro-meter®

TQ922/TQ932, EA902 and IQS900 proximity measurement chains



TQ922 sensor
(standard mount)



TQ932 sensor
(reverse mount)



IQS900
signal conditioner

(Images not to scale)



KEY FEATURES AND BENEFITS

- From the vibro-meter® product line
- Non-contact measurement based on eddy-current principle
- Available in standard versions and Ex versions certified for use in hazardous areas (potentially explosive atmospheres)
- Conforms to API 670 5th edition
- TQ922 and TQ932 sensors withstand up to 100 bar
- 1, 5 and 10 m measurement chains
- Temperature-compensated design
- Voltage output or current output with short-circuit protection
- Current-signal transmission over distances up to 1 km
- Frequency response: DC to 20 kHz (-3 dB)
- Linear measurement range: 2 or 4 mm
- Temperature range (sensor): -25 to 140°C

KEY FEATURES AND BENEFITS (continued)

- Optional diagnostic circuitry detects sensor, cabling and/or signal conditioner problems
- Suitable for use in functional safety contexts: SIL 2 in accordance with IEC 61508 and Cat 1 PL c in accordance with ISO 13849
- IQS900: Removable screw-terminal connectors and DIN-rail mounting

APPLICATIONS

- Shaft relative vibration and gap/position measurement chains for machinery protection and/or condition monitoring
- Ideal for use with VM600^{Mk2}/VM600 and VibroSmart® machinery monitoring systems
- API 670 applications
- High-pressure applications
- Safety-related applications
- Speed (tachometer) sensor/measurement chain for overspeed detection system (ODS) applications



Information contained in this document may be subject to export control regulations of the European Union, USA or other countries. Each recipient of this document is responsible for ensuring that transfer or use of any information contained in this document complies with all relevant export control regulations. ECN N/A.

DESCRIPTION

Introduction

The TQ922/TQ932, EA902 and IQS900 form proximity measurement chains, from Meggitt's vibro-meter[®] product line.

TQ9xx-based proximity measurement chains allow contactless measurement of the relative displacement of moving machine elements, and provide an output signal proportional to the distance between the sensor tip and the target. Accordingly, these measurement chains are ideally suited for measuring the relative vibration and axial position of rotating machine shafts, such as those found in steam, gas and hydraulic turbines, as well as in alternators, turbo-compressors and pumps.

A TQ9xx-based proximity measurement chain consists of a TQ9xx proximity sensor, an optional EA90x extension cable and an IQS900 signal conditioner, configured for a particular industrial application. The EA90x extension cable is used to effectively lengthen the front-end, as required. Together, these form a calibrated proximity measurement chain in which each component is interchangeable.

The IQS900 signal conditioner is a versatile and configurable device that performs all required signal processing and generates the output signal (current or voltage) for input to a machinery monitoring system such as a VM600^{Mk2}/VM600 or VibroSmart[®]. In addition, the IQS900 supports optional diagnostic circuitry (that is, built-in self-test (BIST)) that automatically detects and remotely indicates problems with a measurement chain.

TQ922/TQ932 sensors and cabling

The active part of a TQ9xx proximity sensor is a coil of wire that is moulded inside the tip of the device, made of PPS (polyphenylene sulfide), a high-performance, high-temperature engineering thermoplastic. The sensor body is made of stainless steel. The target material must, in all cases, be metallic.

The TQ922 and TQ932 proximity sensors are essentially the same except that the TQ922 is intended for standard-mount and the TQ932 is for reverse-mount applications. Both sensor bodies are available with metric threads and have an integral coaxial cable terminated with a self-

locking miniature coaxial connector.

A TQ9xx sensor's integral cable and the EA90x extension cables are available in various lengths, which can be combined to obtain a particular total system length (TSL) for an application.

With their sensor tips withstanding pressures of up to 100 bar, the TQ922 and TQ932 proximity sensors are specially designed for high-pressure applications. This makes them particularly suitable for measuring relative displacement or vibration on submerged pumps and various types of hydraulic turbines (for example, Kaplan and Francis).

Optional interconnection protectors (IP172), junction boxes (JB118) and other housings are available for the mechanical and environmental protection of the connection between a TQ9xx sensor's integral cable and an EA90x extension cable.

IQS900 signal conditioner

The IQS900 signal conditioner contains a high-frequency modulator/demodulator that supplies a driving signal to a TQ9xx sensor. This generates an electromagnetic field in the tip of the sensor, which generates eddy-currents in the metallic target. When the target moves, the eddy-currents change, which causes a change in the electrical characteristics of the TQ9xx that the signal conditioner converts into a signal that is proportional to the distance to the target.

The IQS900's output is an analogue signal consisting of a dynamic component (AC) that corresponds to the measured vibration (displacement) and a quasi-static component (DC) that corresponds to the measured gap. The output can be configured as a current or a voltage signal, suitable for transmission to a monitoring system via current (2-wire) or voltage (3-wire) transmission cables, respectively.

For an IQS900 signal conditioner with optional diagnostics, the quasi-static DC component also functions as a diagnostic indicator. That is, the IQS900's diagnostic circuitry continuously checks the integrity of the measurement chain and will drive the measurement/diagnostic component (DC) outside of its normal operating range to indicate a problem with the sensor, the cabling and/or the signal conditioner itself.

DESCRIPTION (continued)

For test purposes, the IQS900 includes a “raw” voltage output signal and a test input signal that allow the measurement chain/system operation to be tested in situ, thereby simplifying commissioning and troubleshooting.

Application information

An IQS900 signal conditioner with diagnostics automatically and remotely indicates the health/status of a TQ9xx-based measurement chain so you always know when measurements can be trusted. This helps to ensure that machinery is operated safely and reliably, extending its life and reducing costs.

Equally important, TQ9xx-based measurement chains using an IQS900 with diagnostics are SIL 2 “by design” so they bring enhanced reliability and significant risk reduction, making them suitable for use in safety-related applications (functional safety contexts).

Further, TQ9xx-based measurement chains are form, fit and functionally equivalent replacements that match or better the outstanding performance of TQ4xx-based measurement chains. Each component is interchangeable, so existing TQ4xx-based proximity measurement chains can be quickly and easily replaced or upgraded. For example, an IQS900 signal conditioner without diagnostics is a direct replacement for an IQS45x in most TQ4xx-based measurement chains.

Note: A TQ9xx-based measurement chain using an IQS900 configured with a current output and a GSI127 galvanic separation unit, allows transmission over distances up to 1 km – longer than any other solution.

For specific applications, contact your local Meggitt representative.

SPECIFICATIONS

Overall proximity measurement chain

Operation

Sensitivity

- Ordering option code B21 : 8 mV/μm (203.2 mV/mil)
- Ordering option code B22 : 2.5 μA/μm (63.5 μA/mil)
- Ordering option code B23 : 4 mV/μm (101.6 mV/mil)
- Ordering option code B24 : 1.25 μA/μm (31.75 μA/mil)

Linear measurement range (typical)

- Ordering option code B21 : 0 to 2.0 mm, corresponding to a –2.4 to –18.4 V output
- Ordering option code B22 : 0 to 2.0 mm, corresponding to a –15.5 to –20.5 mA output
- Ordering option code B23 : 0 to 4.0 mm, corresponding to a –2.4 to –18.4 V output
- Ordering option code B24 : 0 to 4.0 mm, corresponding to a –15.5 to –20.5 mA output

Linearity : See **Performance curves on page 9**

Frequency response : DC to 20 kHz (–3 dB)

Interchangeability of elements : All components in chain are interchangeable

SPECIFICATIONS (continued)

Environmental

Potentially explosive atmospheres

Available in Ex approved versions for use in hazardous areas (**ordering option code A5**)

Protection mode	TQ9xx	EA90x	IQS9xx
Europe			
ec (Gas)	ⓧ II 3 G (Zone 2) Ex ec IIC T6...T3 Gc LCIE 21 ATEX 1004 X T6: For $-40^{\circ}\text{C} \leq T_{\text{amb}} \leq +75^{\circ}\text{C}$ T5: For $-40^{\circ}\text{C} \leq T_{\text{amb}} \leq +90^{\circ}\text{C}$ T4: For $-40^{\circ}\text{C} \leq T_{\text{amb}} \leq +125^{\circ}\text{C}$ T3: For $-40^{\circ}\text{C} \leq T_{\text{amb}} \leq +180^{\circ}\text{C}$	Suitable for Zones 0, 1, 2*	ⓧ II 3 G (Zone 2) Ex ec IIC T6 or T5 Gc LCIE 21 ATEX 1004 X T6: For $-40^{\circ}\text{C} \leq T_{\text{amb}} \leq +70^{\circ}\text{C}$ T5: For $-40^{\circ}\text{C} \leq T_{\text{amb}} \leq +85^{\circ}\text{C}$
ia (Gas)	Suitable for Zones 0, 1, 2. Simple apparatus* .	Suitable for Zones 0, 1, 2*	ⓧ II 1 G (Zones 0, 1, 2) Ex ia IIC T6 or T5 Ga LCIE 21 ATEX 3002 X T6: For $-40^{\circ}\text{C} \leq T_{\text{amb}} \leq +70^{\circ}\text{C}$ T5: For $-40^{\circ}\text{C} \leq T_{\text{amb}} \leq +85^{\circ}\text{C}$
ia (Dust)	Suitable for Zones 20, 21, 22. Simple apparatus* .	Suitable for Zones 20, 21, 22*	ⓧ II 1 D (Zones 20, 21, 22) Ex ia IIIC T ₂₀₀ 80°C...T ₂₀₀ 115°C Da LCIE 21 ATEX 3002 X T ₂₀₀ 80°C: For $-40^{\circ}\text{C} \leq T_{\text{amb}} \leq +50^{\circ}\text{C}$ T ₂₀₀ 95°C: For $-40^{\circ}\text{C} \leq T_{\text{amb}} \leq +65^{\circ}\text{C}$ T ₂₀₀ 115°C: For $-40^{\circ}\text{C} \leq T_{\text{amb}} \leq +85^{\circ}\text{C}$
*Means that the product is not required to be certified. Meggitt SA assumes respect of the Ex standards for these components when connected to an Ex certified IQS9xx.			





International			
ec (Gas)	Ex ec IIC T6...T3 Gc IECEx LCIE 21.0005X T6: For $-40^{\circ}\text{C} \leq T_{\text{amb}} \leq +75^{\circ}\text{C}$ T5: For $-40^{\circ}\text{C} \leq T_{\text{amb}} \leq +90^{\circ}\text{C}$ T4: For $-40^{\circ}\text{C} \leq T_{\text{amb}} \leq +125^{\circ}\text{C}$ T3: For $-40^{\circ}\text{C} \leq T_{\text{amb}} \leq +180^{\circ}\text{C}$	Suitable for Zones 0, 1, 2*	Ex ec IIC T6 or T5 Gc IECEx LCIE 21.0005X T6: For $-40^{\circ}\text{C} \leq T_{\text{amb}} \leq +70^{\circ}\text{C}$ T5: For $-40^{\circ}\text{C} \leq T_{\text{amb}} \leq +85^{\circ}\text{C}$
ia (Gas)	Suitable for Zones 0, 1, 2. Simple apparatus* .	Suitable for Zones 0, 1, 2*	Ex ia IIC T6 or T5 Ga IECEx LCIE 21.0006X T6: For $-40^{\circ}\text{C} \leq T_{\text{amb}} \leq +70^{\circ}\text{C}$ T5: For $-40^{\circ}\text{C} \leq T_{\text{amb}} \leq +85^{\circ}\text{C}$
ia (Dust)	Suitable for Zones 20, 21, 22. Simple apparatus* .	Suitable for Zones 20, 21, 22*	Ex ia IIIC T ₂₀₀ 80°C...T ₂₀₀ 115°C Da IECEx LCIE 21.0006X T ₂₀₀ 80°C: For $-40^{\circ}\text{C} \leq T_{\text{amb}} \leq +50^{\circ}\text{C}$ T ₂₀₀ 95°C: For $-40^{\circ}\text{C} \leq T_{\text{amb}} \leq +65^{\circ}\text{C}$ T ₂₀₀ 115°C: For $-40^{\circ}\text{C} \leq T_{\text{amb}} \leq +85^{\circ}\text{C}$
*Means that the product is not required to be certified. Meggitt SA assumes respect of the Ex standards for these components when connected to an Ex certified IQS9xx.			

SPECIFICATIONS (continued)

Protection mode	TQ9xx	EA90x	IQS9xx
North America			
ec (Gas)	Class I, Division 2, Groups A, B, C, D T6...T3 Ex ec IIC T6...T3 Gc Class I, Zone 2, AEx ec IIC T6...T3 Gc cCSAus 80084516	Suitable for Zones 0, 1, 2*	Class I, Division 2, Groups A, B, C, D T6...T5 Ex ec IIC T6...T5 Gc Class I, Zone 2, AEx ec IIC T6...T5 Gc cCSAus 80084516
ia (Gas)	Suitable for Zones 0, 1, 2. Simple apparatus* .	Suitable for Zones 0, 1, 2*	IS Class I, Division 1, Groups A, B, C, D T6 or T5 Ex ia IIC T6 or T5 Ga Class I, Zone 0, AEx ia IIC T6 or T5 Ga cCSAus 80084516
ia (Dust)	Suitable for Zones 20, 21, 22. Simple apparatus* .	Suitable for Zones 20, 21, 22*	Class II, Division 1, Groups E, F, G T80°C...T115°C Ex ia IIIC T80°C...T115°C Da Zone 20, AEx ia IIIC T80°C...T115°C Da cCSAus 80084516
*Means that the product is not required to be certified. Meggitt SA assumes respect of the Ex standards for these components when connected to an Ex certified IQS9xx.			



South Korea			
ec (Gas)	Ex ec IIC T6...T3 Gc KGS 21-GA4BO-0354X T6: For $-40^{\circ}\text{C} \leq T_{\text{amb}} \leq +75^{\circ}\text{C}$ T5: For $-40^{\circ}\text{C} \leq T_{\text{amb}} \leq +90^{\circ}\text{C}$ T4: For $-40^{\circ}\text{C} \leq T_{\text{amb}} \leq +125^{\circ}\text{C}$ T3: For $-40^{\circ}\text{C} \leq T_{\text{amb}} \leq +180^{\circ}\text{C}$	Suitable for Zones 0, 1, 2*	Ex ec IIC T6...T5 Gc KGS 21-GA4BO-0355X T6: For $-40^{\circ}\text{C} \leq T_{\text{amb}} \leq +70^{\circ}\text{C}$ T5: For $-40^{\circ}\text{C} \leq T_{\text{amb}} \leq +85^{\circ}\text{C}$
ia (Gas)	Suitable for Zones 0, 1, 2. Simple apparatus* .	Suitable for Zones 0, 1, 2*	Ex ia IIC T6 or T5 Ga KGS 21-GA4BO-0353X T6: For $-40^{\circ}\text{C} \leq T_{\text{amb}} \leq +70^{\circ}\text{C}$ T5: For $-40^{\circ}\text{C} \leq T_{\text{amb}} \leq +85^{\circ}\text{C}$
ia (Dust)	Suitable for Zones 20, 21, 22. Simple apparatus* .	Suitable for Zones 20, 21, 22*	Ex ia IIIC T ₂₀₀ 80°C...T ₂₀₀ 115°C Da KGS 21-GA4BO-0352X T ₂₀₀ 80°C: For $-40^{\circ}\text{C} \leq T_{\text{amb}} \leq +50^{\circ}\text{C}$ T ₂₀₀ 95°C: For $-40^{\circ}\text{C} \leq T_{\text{amb}} \leq +65^{\circ}\text{C}$ T ₂₀₀ 115°C: For $-40^{\circ}\text{C} \leq T_{\text{amb}} \leq +85^{\circ}\text{C}$
*Means that the product is not required to be certified. Meggitt SA assumes respect of the Ex standards for these components when connected to an Ex certified IQS9xx.			

SPECIFICATIONS (continued)

Protection mode	TQ9xx	EA90x	IQS9xx
United Kingdom**			
ec (Gas)	 II 3 G (Zone 2) Ex ec IIC T6...T3 Gc CML 21 UKEX 4549 X T6: For $-40^{\circ}\text{C} \leq T_{\text{amb}} \leq +75^{\circ}\text{C}$ T5: For $-40^{\circ}\text{C} \leq T_{\text{amb}} \leq +90^{\circ}\text{C}$ T4: For $-40^{\circ}\text{C} \leq T_{\text{amb}} \leq +125^{\circ}\text{C}$ T3: For $-40^{\circ}\text{C} \leq T_{\text{amb}} \leq +180^{\circ}\text{C}$	Suitable for Zones 0, 1, 2*	 II 3 G (Zone 2) Ex ec IIC T6 or T5 Gc CML 21 UKEX 4549 X T6: For $-40^{\circ}\text{C} \leq T_{\text{amb}} \leq +70^{\circ}\text{C}$ T5: For $-40^{\circ}\text{C} \leq T_{\text{amb}} \leq +85^{\circ}\text{C}$
ia (Gas)	Suitable for Zones 0, 1, 2. Simple apparatus* .	Suitable for Zones 0, 1, 2*	 II 1 G (Zones 0, 1, 2) Ex ia IIC T6 or T5 Ga CML 21 UKEX 2548 X T6: For $-40^{\circ}\text{C} \leq T_{\text{amb}} \leq +70^{\circ}\text{C}$ T5: For $-40^{\circ}\text{C} \leq T_{\text{amb}} \leq +85^{\circ}\text{C}$
ia (Dust)	Suitable for Zones 20, 21, 22. Simple apparatus* .	Suitable for Zones 20, 21, 22*	 II 1 D (Zones 20, 21, 22) Ex ia IIIC T ₂₀₀ 80°C...T ₂₀₀ 115°C Da CML 21 UKEX 2548 X T ₂₀₀ 80°C: For $-40^{\circ}\text{C} \leq T_{\text{amb}} \leq +50^{\circ}\text{C}$ T ₂₀₀ 95°C: For $-40^{\circ}\text{C} \leq T_{\text{amb}} \leq +65^{\circ}\text{C}$ T ₂₀₀ 115°C: For $-40^{\circ}\text{C} \leq T_{\text{amb}} \leq +85^{\circ}\text{C}$
*Means that the product is not required to be certified. Meggitt SA assumes respect of the Ex standards for these components when connected to an Ex certified IQS9xx. **Not engraved/marked on the products.			

Russian Federation			
ec (Gas)	2Ex e IIC T6...T3 Gc X EAЭC RU C-CH.AД07.B.03744/21 T6: For $-40^{\circ}\text{C} \leq T_{\text{amb}} \leq +75^{\circ}\text{C}$ T5: For $-40^{\circ}\text{C} \leq T_{\text{amb}} \leq +90^{\circ}\text{C}$ T4: For $-40^{\circ}\text{C} \leq T_{\text{amb}} \leq +125^{\circ}\text{C}$ T3: For $-40^{\circ}\text{C} \leq T_{\text{amb}} \leq +180^{\circ}\text{C}$	Suitable for Zones 0, 1, 2*	2Ex e IIC T6...T5 Gc X EAЭC RU C-CH.AД07.B.03744/21 T6: For $-40^{\circ}\text{C} \leq T_{\text{amb}} \leq +70^{\circ}\text{C}$ T5: For $-40^{\circ}\text{C} \leq T_{\text{amb}} \leq +85^{\circ}\text{C}$
ia (Gas)	Suitable for Zones 0, 1, 2. Simple apparatus* .	Suitable for Zones 0, 1, 2*	0Ex ia IIC T6...T5 Ga X EAЭC RU C-CH.AД07.B.03744/21 T6: For $-40^{\circ}\text{C} \leq T_{\text{amb}} \leq +70^{\circ}\text{C}$ T5: For $-40^{\circ}\text{C} \leq T_{\text{amb}} \leq +85^{\circ}\text{C}$
ia (Dust)	Suitable for Zones 20, 21, 22. Simple apparatus* .	Suitable for Zones 20, 21, 22*	Ex ia IIIC T ₂₀₀ 80°C...T ₂₀₀ 115°C Da X EAЭC RU C-CH.AД07.B.03744/21 T ₂₀₀ 80°C: For $-40^{\circ}\text{C} \leq T_{\text{amb}} \leq +50^{\circ}\text{C}$ T ₂₀₀ 95°C: For $-40^{\circ}\text{C} \leq T_{\text{amb}} \leq +65^{\circ}\text{C}$ T ₂₀₀ 115°C: For $-40^{\circ}\text{C} \leq T_{\text{amb}} \leq +85^{\circ}\text{C}$
*Means that the product is not required to be certified. Meggitt SA assumes respect of the Ex standards for these components when connected to an Ex certified IQS9xx.			

SPECIFICATIONS *(continued)*

-  For specific parameters of the mode of protection concerned and special conditions for safe use, refer to the Ex certificates that are available from Meggitt SA.
-  For an IQS9xx signal conditioner with protection mode “Ex ec” located in an Ex Zone 2, the user must ensure that the IQS9xx is installed in an industrial housing or enclosure that ensures a protection rating of at least IP54 (or equivalent).
-  For the most recent information on the Ex certifications that are applicable to this product, refer to the Ex product register (PL-1511) document that is available from Meggitt SA.

Approvals

Conformity	: European Union (EU) declaration of conformity (CE marking). United Kingdom (UKCA) declaration of conformity. EAC marking, Eurasian Customs Union (EACU) certificate/ declaration of conformity
Electromagnetic compatibility (EMC)	: EN 61000-6-2:2005. EN 61000-6-4:2007 + A1:2011. EN 61326-1:2013. EN 61326-3-2:2008 (SIL).
Electrical safety	: EN/IEC 61010-1:2010. CAN/CSA C22.2 61010-1-12 / UL 61010-1:2012.
Environmental management Hazardous areas	: RoHS compliant (2011/65/EU) : Ex approved versions (see Potentially explosive atmospheres on page 4)
Functional safety	: SIL 2 in accordance with IEC 61508-1:2010 and IEC 61508-2:2010. Cat 1 PL c in accordance with ISO 13849-1:2015.
Machinery protection systems	: API 670 5th edition compliant

SPECIFICATIONS *(continued)*

System (chain) calibration

Calibration temperature	: +23°C ±5°C
Target material	: VCL 140 steel (1.7225)

Note: For applications using a non-standard or special target material, performance curves can be generated and supplied. Contact Meggitt SA for further information.

Total system (chain) length

The total system length (TSL) is the sum of the length of the TQ9xx sensor's integral cable and the length of the EA90x extension cable. For TQ922/TQ932, EA902 and IQS900 proximity measurement chains, the supported TSLs are obtained from the following different combinations of cables.

Total system (chain) lengths

• 1 m	: 1.0 m integral cable with no extension cable
• 5 m	: 1.0 m integral cable + 4.0 m extension cable. 5.0 m integral cable with no extension cable.
• 10 m	: 1.0 m integral cable + 9.0 m extension cable. 5.0 m integral cable + 5.0 m extension cable. 10.0 m integral cable with no extension cable.

Note: The combination of cables selected for a particular total system (chain) length depends on the application. For example, to obtain the optimum location for the separation between the integral and extension cables or to eliminate the requirement for an extension cable.

Total system (chain) length trimming

Due to the characteristics of the coaxial cable, an "electrical trimming" of the nominal length of extension cables is necessary to optimize the system performance and the sensor interchangeability.

TSL for a 1 m measurement chain	: 0.9 m min.
TSL for a 5 m measurement chain	: 4.4 m min.
TSL for a 10 m measurement chain	: 8.8 m min.

In-situ test support

Raw output	: The raw output (RAW/COM) provides a "raw" voltage output signal that corresponds to the internal signals of the IQS900 signal conditioner, even if the IQS900 is configured with a current output. This allows the measurement chain/system operation from sensor to signal conditioner to be easily verified in situ (see Raw output (RAW/COM) on page 12).
Test input	: The test input (TEST/COM) allows a voltage input signal to be injected at the input to the IQS900 signal conditioner in order to test the IQS900 itself and/or cabling to the monitoring system. This allows the measurement chain/system operation from signal conditioner to monitoring system to be easily verified in situ (see Test input (TEST/COM) on page 13).

Note: See **Connectors on page 14** and refer to the *Proximity measurement chains using TQ9xx proximity sensors installation manual* for further information

SPECIFICATIONS (continued)

Performance curves for TQ922 or TQ932 with IQS900 – 2 mm measurement range

Typical gap error (μm)
(Referenced to 8 mV/ μm
(2.5 $\mu\text{A}/\mu\text{m}$) line)

Typical sensitivity error (%)
(Referenced to 8 mV/ μm
(2.5 $\mu\text{A}/\mu\text{m}$))

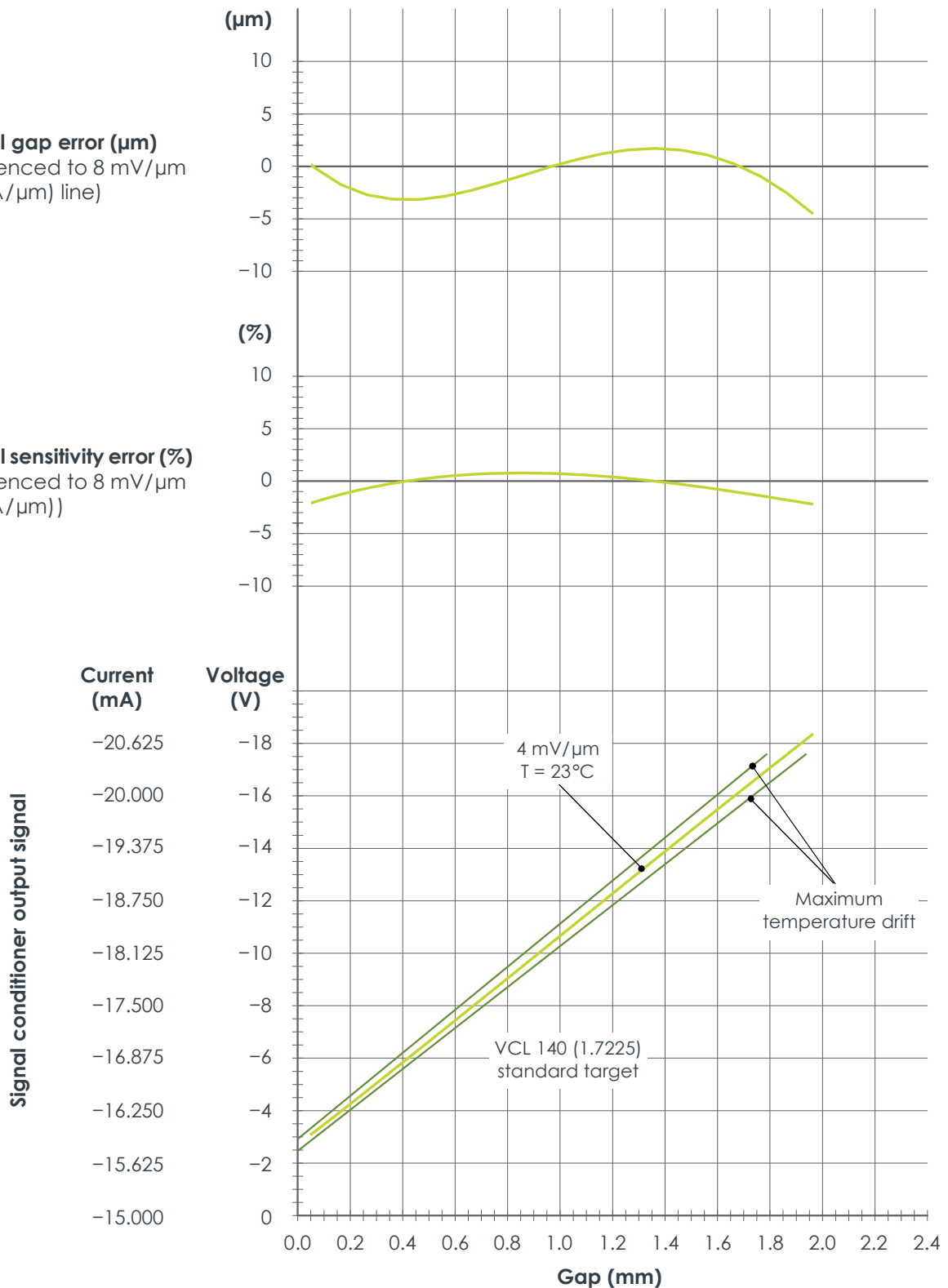

Proximity sensor: TQ922 or TQ932
Signal conditioner: IQS900 (ordering option code B21 or B22)
Standard target material: VCL 140 (1.7225)
Equivalent materials: A 37.11 (1.0065), AFNOR 40 CD4, AISI 4140

SPECIFICATIONS (continued)

Performance curves for TQ922 or TQ932 with IQS900 – 4 mm measurement range

Typical gap error (μm)
(Referenced to 4 mV/ μm
(1.25 $\mu\text{A}/\mu\text{m}$) line)

Typical sensitivity error (%)
(Referenced to 4 mV/ μm
(1.25 $\mu\text{A}/\mu\text{m}$))

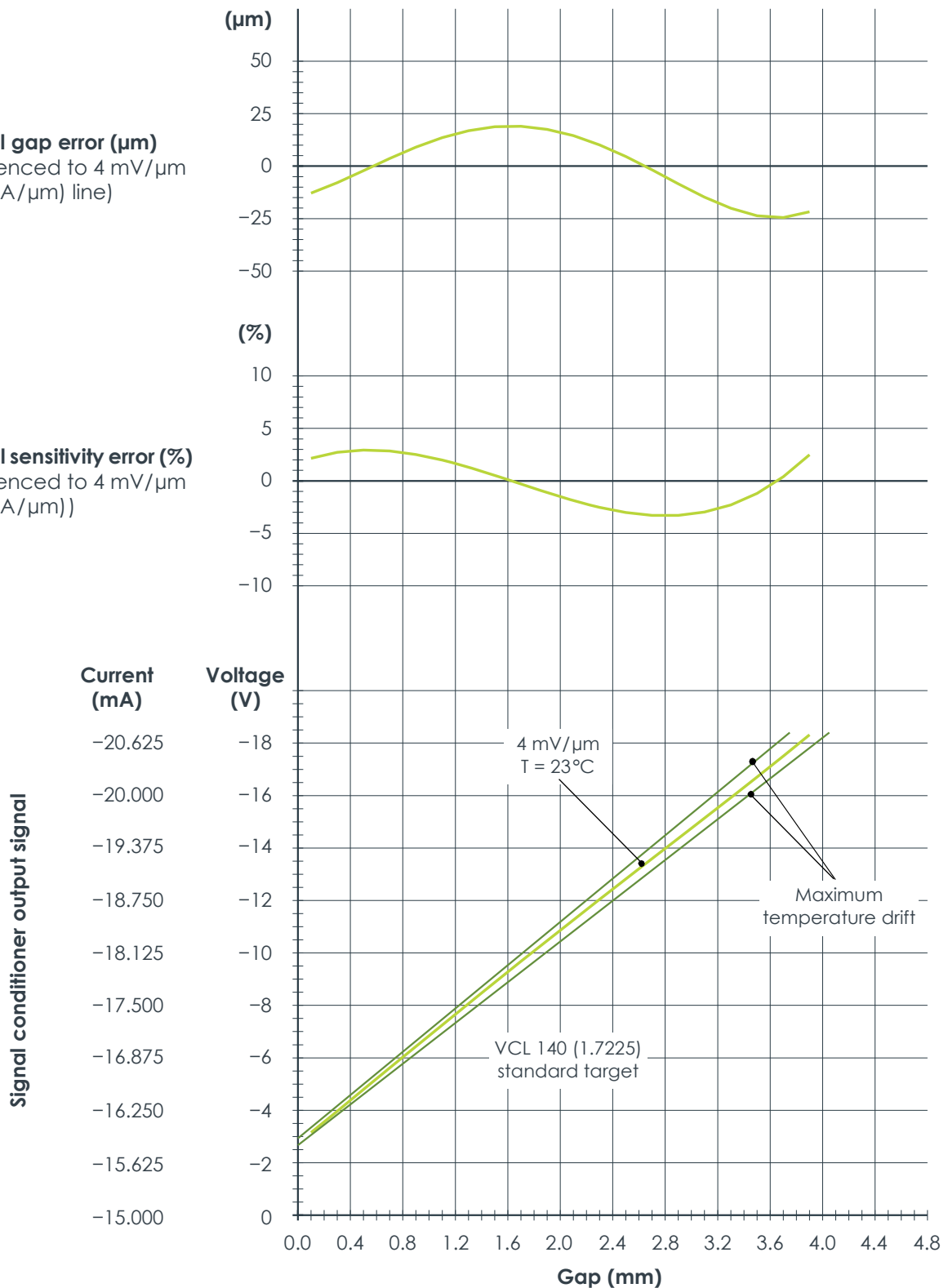

Proximity sensor: TQ922 or TQ932
 Signal conditioner: IQS900 (ordering option code B23 or B24)
 Standard target material: VCL 140 (1.7225)
 Equivalent materials: A 37.11 (1.0065), AFNOR 40 CD4, AISI 4140

SPECIFICATIONS *(continued)*

TQ922 and TQ932 proximity sensors and EA902 extension cable

General

Sensor input requirements : High-frequency power source from an IQS900 signal conditioner

Environmental

Temperature range

- Sensor : -25 to 140°C (-13 to 284°F) operating
- Sensor and cabling : **Temperature for use in an Ex Zone: see Potentially explosive atmospheres on page 4**
- Cabling, connector and optional protection : -40 to 200°C (-40 to 392°F)

Measurement drift

- Sensor and cabling with a total system (chain) length of 1, 5 or 10 m : <5% for -25 to 140°C (-13 to 284°F)

Pressure

- Sensor tip : 100 bar max.
- Sensor and integral cable assembly : 10 bar max.

Protection rating
(according to IEC 60529)

: The head of the sensor (sensor tip and integral cable) is rated IP68

Vibration
(according to IEC 60068-2-26)

: 5 g peak between 10 and 500 Hz

Shock acceleration
(according to IEC 60068-2-27)

: 15 g peak (half sine-wave, 11 ms duration)

Physical characteristics

Sensor construction : Wire coil Ø8 mm, PPS (polyphenylene sulfide) high-performance thermoplastic tip, encapsulated in a stainless-steel body (AISI 316L)

Integral and extension cables : FEP covered 70 Ω coaxial cable, Ø3.6 mm

Connectors : Self-locking miniature coaxial connectors.
Note: When connecting, these should be hand-tightened until locked.

Optional protection

- Flexible stainless-steel hose (protection tube) with FEP sheath (extruded fluorinated ethylene propylene) : The combination of stainless-steel hose with FEP sheath provides sealed (leak-tight) mechanical and electrically insulated protection.
Note: The FEP sheath also provides resistance to almost all chemicals and low permeability to liquids, gases and moisture, while being flexible, low friction and mechanically tough.

SPECIFICATIONS *(continued)*

IQS900 signal conditioner

Current output (2-wire signal transmission)

Current at min. / max. gap	: -15.5 mA / -20.5 mA
Measurement range	: 5 mA (corresponding to 2 or 4 mm)
Output sensitivity	: See Operation on page 3 and IQS900 signal conditioner on page 18
Nominal output signal	
• Without diagnostics	: -15.5 to -20.5 mA
• With diagnostics	: -15.5 to -20.5 mA indicates normal operation. Other current values (>-15.5 or <-20.5 mA) indicate a problem with the measurement chain (sensor, cabling or signal conditioner).
Output impedance	: $>60\ \Omega$. Note: Recommended monitoring system input impedance: $\leq 350\ \Omega$.

Voltage output (3-wire signal transmission)

Voltage at min. / max. gap	: -2.4 V / -18.4 V
Measurement range	: 16 V (corresponding to 2 or 4 mm)
Output sensitivity	: See Operation on page 3 and IQS900 signal conditioner on page 18
Nominal output signal	
• Without diagnostics	: -2.4 to -18.4 V
• With diagnostics	: -2.4 to -18.4 V indicates normal operation. Other voltage values (>-2.4 or <-18.4 V) indicate a problem with the measurement chain (sensor, cabling or signal conditioner).
Output impedance (small signal)	: $<100\ \Omega$ at DC. $<300\ \Omega$ at 20 kHz. Note: Recommended monitoring system input impedance: $\geq 50\ \Omega$. The low output impedance enables operation with a wider range of galvanic separation units / safety barriers, without loss of performance. For example, an IQS900 (output impedance $100\ \Omega$) connected to a third-party galvanic isolator (input impedance $10\ \text{k}\Omega$) will see 1% max. signal loss due to impedance matching.
Protection	: Short-circuit (35 mA), overvoltage ($-33\ V_{DC}$ typical)
Output voltage swing	: -0.05 to -22.5 V with a $50\ \text{k}\Omega$ load and a $-24\ V_{DC}$ power supply. -0.05 to -21.5 V with a $10\ \text{k}\Omega$ load and a $-24\ V_{DC}$ power supply.

Raw output (RAW/COM)

Output voltage range	: -0.8 to -8.8 V (nominal)
Output impedance	: $<15\ \text{k}\Omega$ up to 20 kHz. $<10\ \text{k}\Omega$ for DC measurement. Note: Recommended test equipment input impedance: $>1\ \text{M}\Omega$.
Protection	: Short-circuit, overvoltage ($-33\ V_{DC}$ typical)

SPECIFICATIONS *(continued)*

Test input (TEST/COM)

Transfer function

- Main current output (TEST input to -24V/COM output) : Current output (mA) = $V_{TEST} (V) \times 0.5$
- Main voltage output (TEST input to O/P/COM output) : Voltage output (V) = $V_{TEST} (V) \times 1.6$
- Test voltage output (TEST input to RAW/COM output) : V_{RAW} output (V) = $V_{TEST} (V) \times 0.8$

Input impedance

: 500 k Ω .

Note: Recommended test equipment output impedance: >5 k Ω .

Protection

: Overvoltage (-33 V_{DC} typical)

Power supply (to IQS900)

Input voltage range

- With a current output signal (2-wire signal transmission) : -18 to -30 V_{DC} (nominal)
- With a voltage output signal (3-wire signal transmission) : -19 to -30 V_{DC} (nominal)

Current consumption

: -25 mA max.

(with nominal 24 V_{DC} supply)

-15.5 mA standby.

Overvoltage protection (diode)

: -33 V_{DC} typical

Note: The IQS900 should be powered (energised) using a limited-power, low-voltage power supply such as a sensor power supply output provided a VM600^{Mk2}/VM600 or VibroSmart[®] monitoring and/or protection system, a GSI127 galvanic separation unit or other suitable power supply.

In safety-related applications, an IQS900 must be powered using a limited-power, low-voltage power supply with a safe limitation of -30 V_{DC} (nominal), even in the event of a single fault with the power supply.

Environmental

Temperature

- Operating and storage : -40 to 85°C (-40 to 185°F)

Humidity

: 0 to 95%, non-condensing

Protection rating

: IP20.

(according to IEC 60529)

Note: The IQS900 is suitable for indoor use only unless it is installed in an industrial housing or enclosure that ensures a higher level of environmental protection.

Flammability

: UL94 V-0

Vibration

: 5 g peak between 10 and 500 Hz

(according to IEC 60068-2-6)

Shock acceleration

: 15 g peak (half sine-wave, 11 ms duration)

(according to IEC 60068-2-27)

SPECIFICATIONS *(continued)*

Connectors

Self-locking miniature coaxial connector (bidirectional)	: 1 contact for sensor-side signal: sensor (connects to TQ9xx sensor or EA902 cable)
Screw-terminal connector (input)	: 4 contacts for test signals: raw output (RAW/COM) and test input (TEST/COM)
Screw-terminal connector (output)	: 4 contacts for monitor-side signals: measurement output (O/P/COM) and power supply input (-24V/COM)
Screw-terminal connectors	
• Clamping range (min. to max.)	: 0.2 to 1.5 mm ² (28 to 16 AWG)
• Tightening torque (min. to max.)	: 0.2 to 0.25 N•m (0.15 to 0.18 lb-ft) for conductor screws. 0.2 to 0.3 N•m (0.15 to 0.22 lb-ft) for mounting-flange screws.

Note: The IQS900 features removal screw-terminal connectors that can unplugged from the main body of its housing to simplify installation and mounting.

Physical characteristics

Electrical connections	: Self-locking miniature coaxial connector and removable screw-terminal connectors (see Connectors on page 14)
Housing material	: Injection-moulded aluminium, painted
Dimensions	: See Mechanical drawings and ordering information on page 18
Weight	: 200 g (0.44 lb) approx.
Mounting	
• Without DIN-rail mounting adaptor	: Two M4 screws
• With DIN-rail mounting adaptor (ordering option code I1)	: MA130 DIN-rail mounting adaptor for signal conditioners. Suitable for TH 35 DIN rails (according to EN 50022 / IEC 60715). For example, TH 35-7.5 or TH 35-15. See Accessories on page 19 .

MECHANICAL DRAWINGS AND ORDERING INFORMATION

TQ922 proximity sensor

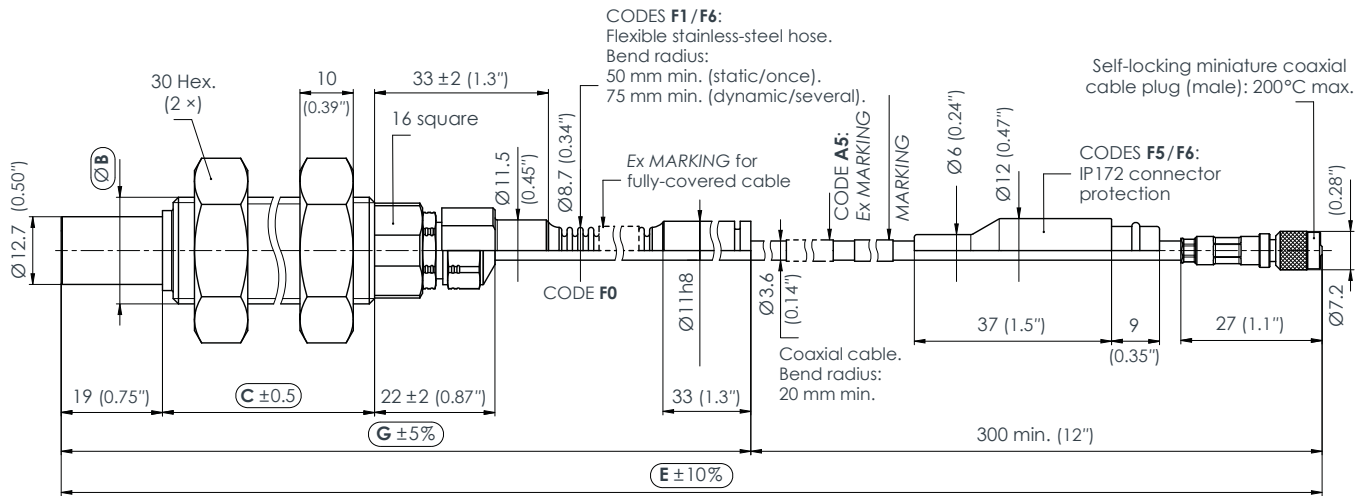

Ordering number:

111 - 922 - 000 - 011

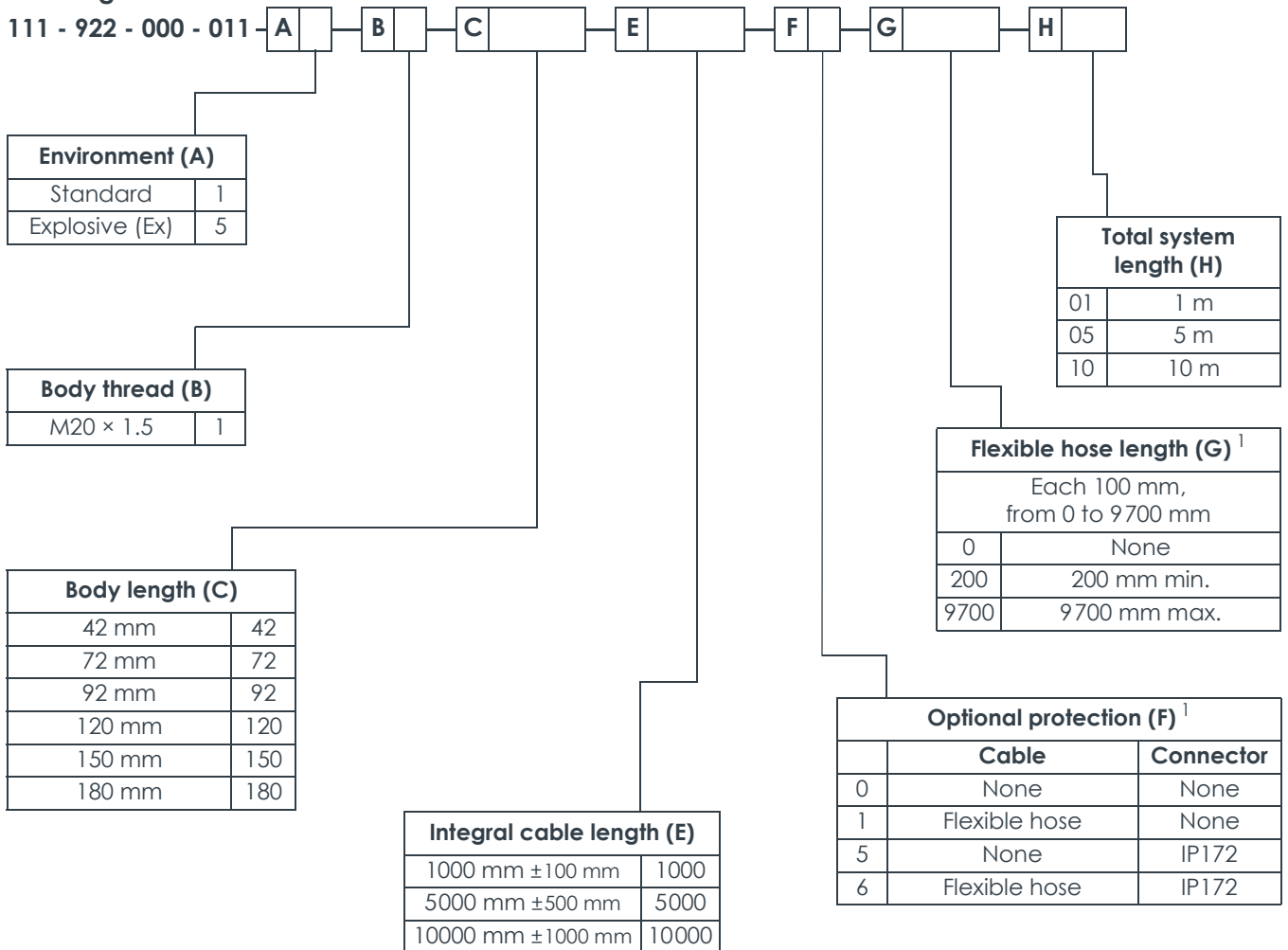

Notes

All dimensions are in mm (in) unless otherwise stated.

1. When optional protection such as a flexible stainless-steel hose is ordered:

Flexible hose length (G) min. = Body length (C) + 100 mm.

Flexible hose length (G) max. = Integral cable length (E) - 300 mm, for an integral cable that is protected to the maximum extent possible ("fully-covered cable").

MECHANICAL DRAWINGS AND ORDERING INFORMATION (continued)

TQ932 proximity sensor

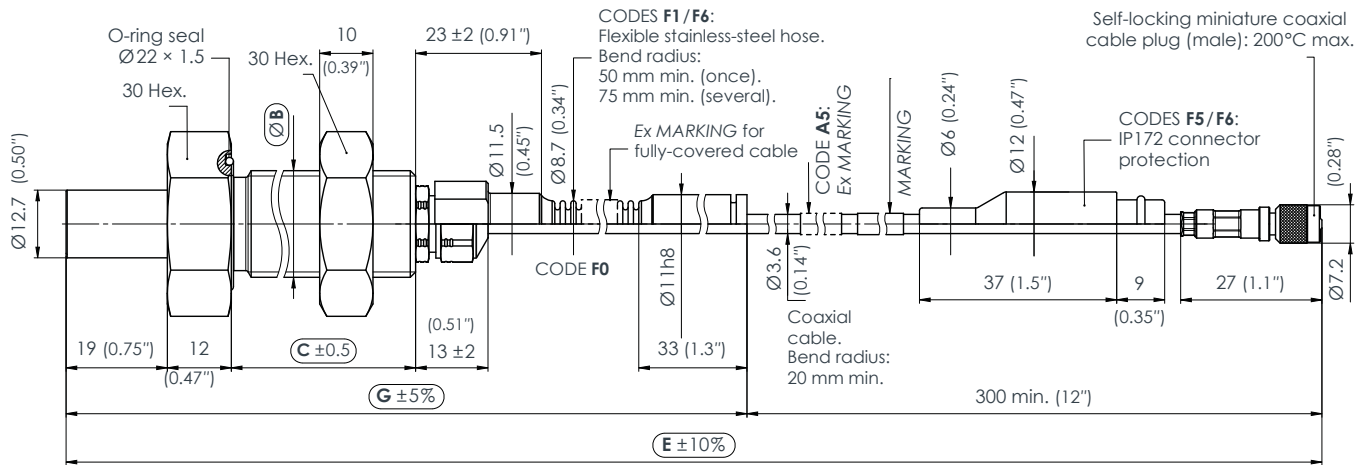

Ordering number:

111 - 932 - 000 - 011



Environment (A)	
Standard	1
Explosive (Ex)	5

Body thread (B)	
M20 × 1.5	1

Body length (C)	
42 mm	42

Integral cable length (E)	
1000 mm ±100 mm	1000
5000 mm ±500 mm	5000
10000 mm ±1000 mm	10000

Total system length (H)	
01	1 m
05	5 m
10	10 m

Flexible hose length (G) ¹	
Each 100 mm, from 0 to 9700 mm	
0	None
200	200 mm min.
9700	9700 mm max.

Optional protection (F) ¹		
	Cable	Connector
0	None	None
1	Flexible hose	None
5	None	IP172
6	Flexible hose	IP172

Notes

All dimensions are in mm (in) unless otherwise stated.

1. When optional protection such as a flexible stainless-steel hose with FEP sheath is ordered:

Flexible hose length (G) min. = Body length (C) + 100 mm.

Flexible hose length (G) max. = Integral cable length (E) - 300 mm, for an integral cable that is protected to the maximum extent possible ("fully-covered cable").

MECHANICAL DRAWINGS AND ORDERING INFORMATION (continued)

EA902 extension cable

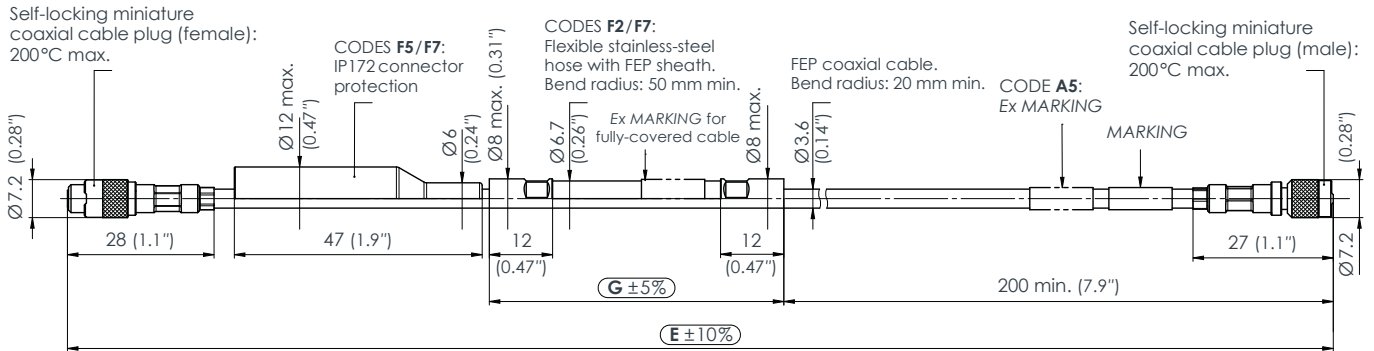

Ordering number:

913 - 902 - 000 - 011 - A - E - F - G

Environment (A)	
Standard	1
Explosive (Ex)	5

Flexible hose length (G) ²	
Each 100 mm, from 0 to 9300 mm.	
0	None
100	100 mm min.
9300	9300 mm max.

Extension cable length (E) ¹	
4000 mm ±400 mm	4000
5000 mm ±500 mm	5000
9000 mm ±900 mm	9000

Optional protection (F) ²		
	Cable	Connector
0	None	None
2	Flexible hose with FEP sheath	None
5	None	IP172
7	Flexible hose with FEP sheath	IP172

Notes

All dimensions are in mm (in) unless otherwise stated.

1. The total system (chain) length = TQ922 or TQ932 integral cable length + EA902 extension cable length (E).
For information on combining integral and extension cables to obtain a particular total system (chain) length, see **Total system (chain) length on page 8**. For information on cable length tolerances, see **Total system (chain) length trimming on page 8**.

2. When optional protection such as a flexible stainless-steel hose with FEP sheath is ordered:
Flexible hose length (G) max. = EA902 extension cable length (E) - 200 mm, for an extension cable that is protected to the maximum extent possible ("fully-covered cable").

MECHANICAL DRAWINGS AND ORDERING INFORMATION (continued)

IQS900 signal conditioner

Side and top views

Note: All dimensions in mm (in) unless otherwise stated.

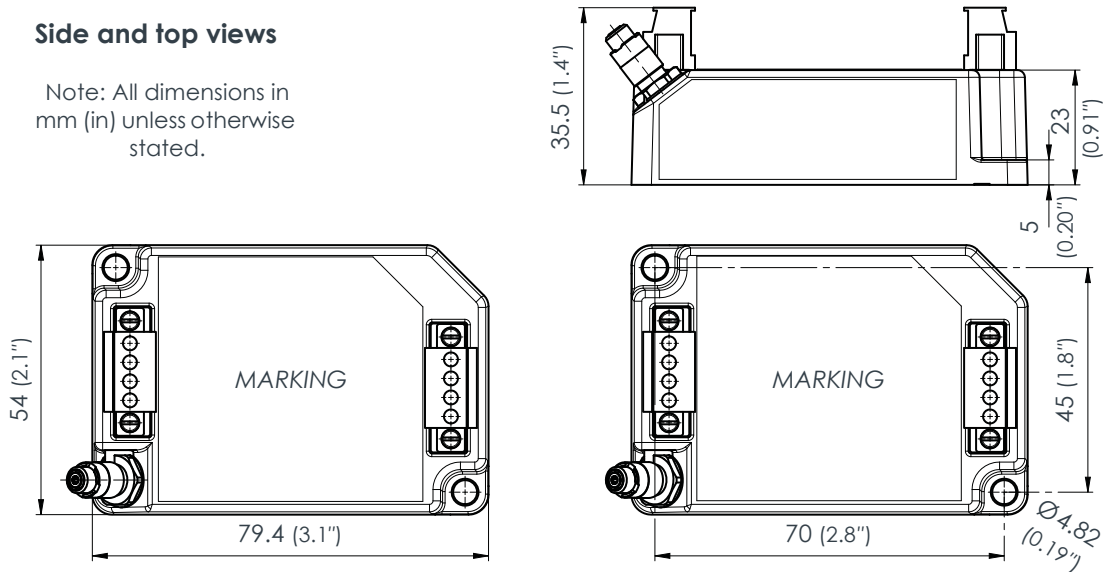

Side and end views with DIN-rail mounting adaptor (ordering option code I1)

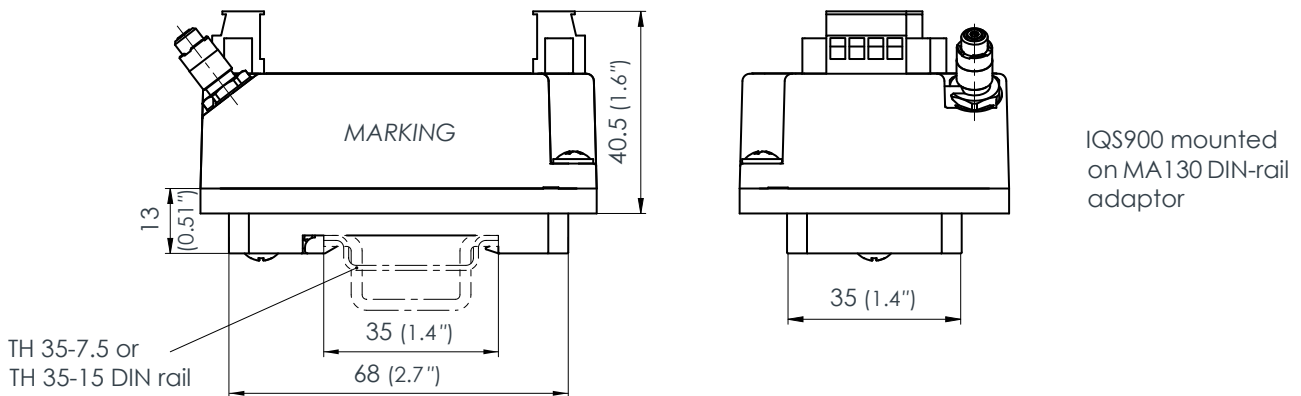

Ordering number: 204 - 900 - 000 - 011 - A - B - C - H - I

Environment (A) ¹	
Standard	1
Explosive (Ex)	5

Measurement range	Sensitivity (B)	
	2 mm	8 mV/μm
	2.5 μA/μm	22
4 mm	4 mV/μm	23
	1.25 μA/μm	24

Diagnostics (C) ²	
Without diagnostics	1
With diagnostics (SIL)	2

Total system length (H)	
1 m	01
5 m	05
10 m	10

Installation (I)	
Without DIN-rail adaptor	0
With DIN-rail adaptor (MA130)	1

Notes
See following page.

MECHANICAL DRAWINGS AND ORDERING INFORMATION *(continued)*

IQS900 signal conditioner *(continued)*

Notes

- Ordering option code **A5** ("Ex") specifies an IQS900 signal conditioner suitable for use in hazardous areas.
 - For an IQS900 signal conditioner with protection mode "Ex" located in an Ex Zone 2, the user must ensure that the IQS900 is installed in an industrial housing or enclosure that ensures a protection rating of at least IP54 (or equivalent).
- Ordering option code **C** specifies an IQS900 signal conditioner either without diagnostics (**C1**) or with diagnostics (**C2**):
 - An IQS900 signal conditioner without diagnostics (**C1**) is similar to the IQS45x, which it replaces. The IQS900 is a form, fit and functionally equivalent replacement that matches or better the measurement specifications of the IQS45x.
 - An IQS900 signal conditioner with diagnostics (**C2**) includes optional diagnostic circuitry that automatically detects and remotely indicates problems with the measurement chain (sensor, cabling and/or the IQS900 itself). An IQS900 with diagnostics is certified SIL 2 (IEC 61508) and Cat 1 PL c (ISO 13849) "by design" to more easily meet the requirements of safety-related applications. Contact Meggitt SA for further information.

ACCESSORIES

ABA17x	Industrial housings	: Refer to corresponding data sheet
IP172	Interconnection protection	: Refer to corresponding data sheet
JB118	Junction box	: Refer to corresponding data sheet
KS107	Flexible conduit (protection tube)	: Refer to corresponding data sheet
MA130	Mounting adaptor	: See below
SG1xx	Cable feedthroughs	: Refer to corresponding data sheets

ACCESSORIES (continued)

MA130 DIN-rail mounting adaptor

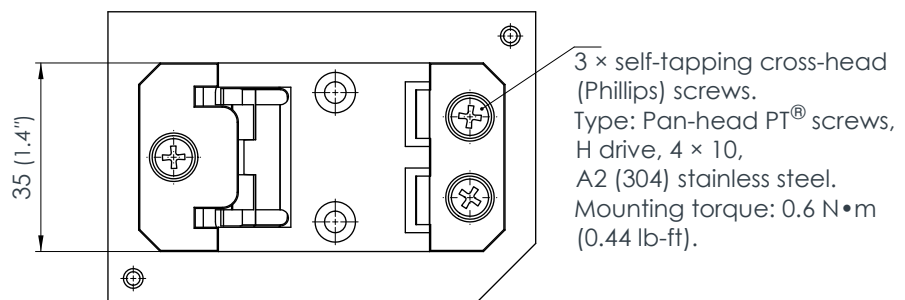
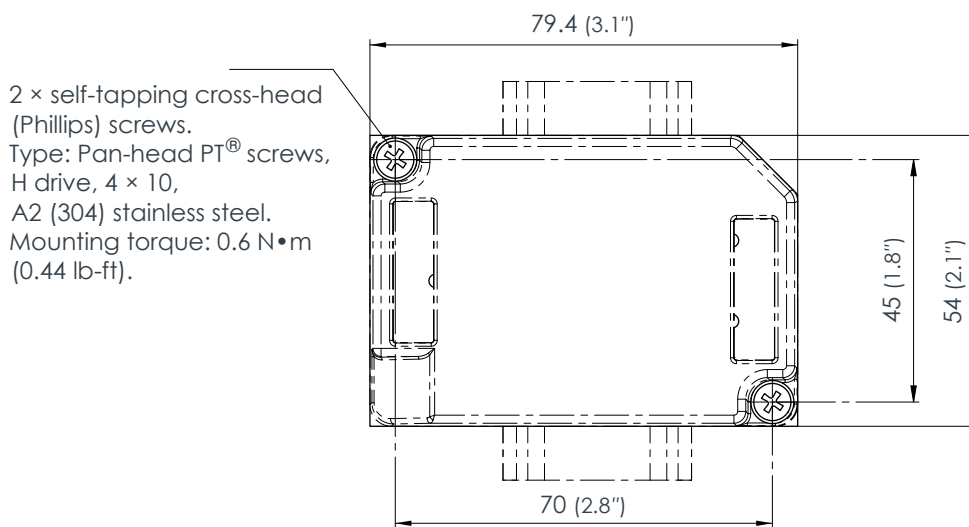
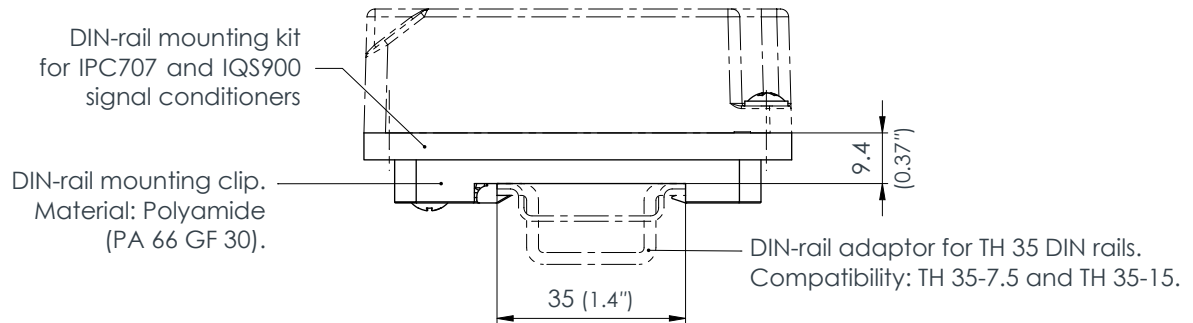

Note: All dimensions in mm (in) unless otherwise stated.

Ordering number (PNR): 809-130-000-021

RELATED PRODUCTS

TQ902/TQ912, EA902 and IQS900	Proximity measurement chains (2 or 4 mm measurement range)	: Refer to corresponding data sheet
TQ942, EA902 and IQS900	Proximity measurement chain (2 or 4 mm measurement range, right-angle (90°) mount)	: Refer to corresponding data sheet
TQ422/TQ432, EA402 and IQS450	Proximity measurement system (2 or 4 mm measurement range, high-pressure applications)	: Refer to corresponding data sheet

Meggitt (Meggitt PLC) is a leading international engineering company, headquartered in England, that designs and delivers high-performance components and subsystems for aerospace, defence and selected energy markets. Meggitt comprises four customer-aligned divisions: Airframe Systems, Engine Systems, Energy & Equipment and Services & Support.

The Energy & Equipment division includes the Energy Sensing and Controls product group that specialises in sensing and monitoring solutions for a broad range of energy infrastructure, and control valves for industrial gas turbines, primarily for the Power Generation, Oil & Gas and Services markets. Energy & Equipment is headquartered in Switzerland (Meggitt SA) and incorporates the vibro-meter® product line, which has over 65 years of sensor and systems expertise and is trusted by original equipment manufacturers (OEMs) globally.



All information in this document, such as descriptions, specifications, drawings, recommendations and other statements, is believed to be reliable and is stated in good faith as being approximately correct, but is not binding on Meggitt (Meggitt SA) unless expressly agreed in writing. Before acquiring and/or using this product, you must evaluate it and determine if it is suitable for your intended application. You should also check our website at www.meggittsensing.com/energy for any updates to data sheets, certificates, product drawings, user manuals, service bulletins and/or other instructions affecting the product.

Unless otherwise expressly agreed in writing with Meggitt SA, you assume all risks and liability associated with use of the product. Any recommendations and advice given without charge, whilst given in good faith, are not binding on Meggitt SA. Meggitt (Meggitt SA) takes no responsibility for any statements related to the product which are not contained in a current Meggitt SA publication, nor for any statements contained in extracts, summaries, translations or any other documents not authored and produced by Meggitt SA.

The certifications and warranties applicable to the products supplied by Meggitt SA are valid only for new products purchased directly from Meggitt SA or from an authorised distributor of Meggitt SA.

In this publication, a dot (.) is used as the decimal separator and thousands are separated by thin spaces. Example: 12345.67890.

Copyright© 2022 Meggitt SA. All rights reserved. The information contained in this document is subject to change without prior notice.

Sales offices

Meggitt has offices in more than 30 countries. For a complete list, please visit our website.

Local representative

Head office

Meggitt SA
Route de Moncor 4
Case postale
1701 Fribourg
Switzerland

Tel: +41 26 407 11 11

Fax: +41 26 407 13 01

energy@ch.meggitt.com

www.meggittsensing.com/energy

www.meggitt.com

